



# MasterConsole CAT (MCCAT28/216)

**User Guide**  
Release 2.1

---

Copyright © 2010 Raritan, Inc.

MCCAT2-0C-v2.1-E

April 2010

255-20-0005-00

---

This document contains proprietary information that is protected by copyright. All rights reserved. No part of this document may be photocopied, reproduced, or translated into another language without express prior written consent of Raritan, Inc.

© Copyright 2010 Raritan, Inc., CommandCenter®, Dominion®, Paragon® and the Raritan company logo are trademarks or registered trademarks of Raritan, Inc. All rights reserved. Java® is a registered trademark of Sun Microsystems, Inc. Internet Explorer® is a registered trademark of Microsoft Corporation. Netscape® and Netscape Navigator® are registered trademarks of Netscape Communication Corporation. All other trademarks or registered trademarks are the property of their respective holders.

#### FCC Information

This equipment has been tested and found to comply with the limits for a Class A digital device, pursuant to Part 15 of the FCC Rules. These limits are designed to provide reasonable protection against harmful interference in a commercial installation. This equipment generates, uses, and can radiate radio frequency energy and if not installed and used in accordance with the instructions, may cause harmful interference to radio communications. Operation of this equipment in a residential environment may cause harmful interference.

#### VCCI Information (Japan)

この装置は、情報処理装置等電波障害自主規制協議会（VCCI）の基準に基づくクラスA情報技術装置です。この装置を家庭環境で使用すると電波妨害を引き起こすことがあります。この場合には使用者が適切な対策を講ずるよう要求されることがあります。

Raritan is not responsible for damage to this product resulting from accident, disaster, misuse, abuse, non-Raritan modification of the product, or other events outside of Raritan's reasonable control or not arising under normal operating conditions.



#### Power Safety Guidelines

To avoid potentially fatal shock hazard and possible damage to Raritan equipment:

- Do not use a 2-wire power cord in any product configuration.
- Test AC outlets at your computer and monitor for proper polarity and grounding.
- Use only with grounded outlets at both the computer and monitor. When using a backup UPS, power the computer, monitor and appliance off the supply.

### **Rack Mount Safety Guidelines**

In Raritan products which require Rack Mounting, please follow these precautions:

- Operation temperature in a closed rack environment may be greater than room temperature. Do not exceed the rated maximum ambient temperature of the appliances. See **Specifications**.
- Ensure sufficient airflow through the rack environment.
- Mount equipment in the rack carefully to avoid uneven mechanical loading.
- Connect equipment to the supply circuit carefully to avoid overloading circuits.
- Ground all equipment properly, especially supply connections, such as power strips (other than direct connections), to the branch circuit.

# Contents

## What's New in the MCCAT User Guide viii

---

### Chapter 1 Introduction 1

---

Product Overview.....	1
MCCAT Switch .....	1
MCCAT User Station .....	2
MCCAT Computer Interface Module (MCIM) .....	2
MCUTP Cable.....	2
Product Photos .....	4
Product Features .....	5
MCCAT Switch .....	5
MCCAT User Station .....	6
Package Contents.....	6
MCCAT Switch .....	7
MCCAT User Station (Optional) .....	7
Structure Diagrams .....	7
MCCAT Switch .....	7
MCCAT User Station .....	9

### Chapter 2 Quick Start 11

---

Rack-Mounting MCCAT Switches .....	11
Attaching the Cable-Support Bar (Optional).....	12
Forward Mount.....	13
Rear Mount .....	14
Basic Installation .....	15
Preparing Requisite Items .....	15
Making the Connection.....	15
Connecting a User Station (Optional) .....	19
Login .....	22
Accessing a Computer or Channel .....	23
Using the Selection Menu.....	24
Using Channel Buttons.....	25
Logout.....	25

### Chapter 3 Introduction to the OSD Interface 26

---

OSD Layout .....	26
Login Box.....	26
OSD Menu .....	27

Activating the OSD.....	29
Variations of Highlight Colors .....	29
Channel Colors .....	29
What are Active and Inactive Channels .....	30
Channel Colors and Statuses.....	31
OSD Operation Keys .....	31

**Chapter 4 Advanced Operation 34**

---

Switching the Channel Sorting.....	35
Cycling Through Channels .....	36
Using the SCAN Button .....	36
Using the F6 Function Key .....	37
Accessing Active Channels Only .....	38
Using the SKIP Button .....	38
Using the F7 Function Key .....	39
Sharing the Computer.....	40
Activating the Help Menu.....	41
Supporting Sun Servers.....	41
Emulating Special Sun Keys .....	42
Refreshing Channel Statuses.....	43

**Chapter 5 System Settings 44**

---

Assigning or Modifying Channel Names.....	45
Changing the Scan Rate.....	46
Renaming the MCCAT Switch .....	46
Changing Passwords.....	47
Changing the Hot Key.....	48
Changing the Operation Mode.....	49
Setting Up the Green Mode .....	50
Setting Up the Logoff Timeout Function .....	51
Hiding the Login Box.....	52
Managing User Accounts.....	53
Renaming User Accounts.....	53
Adding User Accounts .....	53
Deleting User Accounts.....	54
Setting Up the Channel ID Display Function .....	55
Setting Up the ID Display Function.....	55
Adjusting the ID Display Position.....	56
Adjusting the OSD Menu Position .....	57
Resetting System Settings.....	57

**Chapter 6 Two-Tier System 59**

---

Overview .....	59
Establishing a Two-Tier System .....	60
STEP (A): Programme an MCCAT Switch as a Second-Tier Device .....	60
STEP (B): Connect the Second-Tier MCCAT Switch to the Base Switch.....	61
STEP (C): Connect Input/Output Devices to the Base Switch.....	62

STEP (D): Specify the Type of the Second-Tier Device on the OSD.....	64
STEP (E): Connect Computers to the MCCAT System .....	65
Setting Up the Second-Tier Channels .....	65
Accessing the Second-Tier Channels.....	66
Limitations of the Two-Tier System .....	67
Returning to the Base Switch's OSD .....	67
<b>Chapter 7 Keyboard Layout Settings (for Sun USB MCUTP Cable)</b>	<b>68</b>
<hr/>	
Changing Keyboard Layout Settings .....	68
Keyboard Layout Codes .....	70
<b>Chapter 8 User Station Direct Mode</b>	<b>71</b>
<hr/>	
<b>Chapter 9 Firmware Upgrade</b>	<b>73</b>
<hr/>	
STEP (A): Download the Latest Firmware and Upgrade Utility.....	73
STEP (B): Connect the Desired Device to the Computer Running the Upgrade Utility .....	74
STEP (C): Launch the Upgrade Utility .....	75
<b>Appendix A Specifications</b>	<b>78</b>
<hr/>	
Measurement .....	78
Power .....	78
Operating Environment.....	78
Supported Resolutions .....	79
<b>Appendix B Cable Length Limitations</b>	<b>80</b>
<hr/>	
Maximum Distance between Users and MCCAT Switches.....	80
Maximum Distance between Users and Computers .....	80
Maximum Distance for User Station Direct Mode.....	81
<b>Appendix C Compatibility with Other Raritan Products</b>	<b>82</b>
<hr/>	
Compatible KVM Switches .....	82
One-User MCCAT Switches.....	82
TMCAT17 Switches.....	85
Compatible CIMs .....	85
Connecting a Serial Device via the Serial CIM.....	87
P2-EUST User Station.....	89
Supported Maximum Cable Length .....	90

<b>Appendix D Default Settings</b>	<b>91</b>
<hr/>	
<b>Appendix E Troubleshooting</b>	<b>92</b>
<hr/>	
<b>Index</b>	<b>95</b>
<hr/>	

# What's New in the MCCAT User Guide

The following sections have changed or information has been added to the MCCAT User Guide based on enhancements and changes to the equipment and/or user documentation.

- **MCUTP Cable** (on page 2)
- **Product Photos** (on page 4)
- **MCCAT Switch** (on page 5)
- **Preparing Requisite Items** (on page 15)
- **Making the Connection** (on page 15)
- **Supporting Sun Servers** (on page 41)
- **What are Active and Inactive Channels** (on page 30)
  - **Active Channels** (on page 30)
  - **Inactive Channels** (on page 30)
- **Limitations of the Two-Tier System** (on page 67)
- **Keyboard Layout Settings (for Sun USB MCUTP Cable)** (on page 68)
  - **Changing Keyboard Layout Settings** (on page 68)
  - **Keyboard Layout Codes** (on page 70)
- **User Station Direct Mode** (on page 71)
- **Cable Length Limitations** (on page 80)
  - **Maximum Distance between Users and MCCAT Switches** (on page 80)
  - **Maximum Distance between Users and Computers** (on page 80)
  - **Maximum Distance for User Station Direct Mode** (on page 81)
- **Compatible KVM Switches** (on page 82)
  - **One-User MCCAT Switches** (on page 82)
  - **TMCAT17 Switches** (on page 85)

See the Release Notes for a more detailed explanation of the changes applied to this version of the MCCAT.



# Chapter 1 Introduction

Congratulations on purchasing Raritan's *two-user* MasterConsole CAT KVM switch—MCCAT28 or MCCAT216, and/or a MasterConsole CAT (MCCAT) user station. This user guide explains how to use these devices to access and control multiple computers or servers.

## In This Chapter

Product Overview .....	1
Product Photos .....	4
Product Features .....	5
Package Contents .....	6
Structure Diagrams.....	7

---

## Product Overview

MCCAT switch is a KVM (keyboard/video/mouse) switch that enables you to control multiple computers from a single set of keyboard, mouse, and monitor. Connect the keyboard, mouse, monitor and all computers to an MCCAT switch, and you will be able to switch among computers connected to the MCCAT switch. If cascading MCCAT switches to form a two-tier MCCAT system, the number of accessible computers can be expanded up to a maximum of 256 computers.

MCCAT switch features the use of standard Category 5 (Cat5) unshielded twisted-pair (UTP) cables for connecting computers. In terms of operation, it provides front panel buttons for easy and fast access to connected computers in addition to a friendly OSD (On-Screen Display) interface for simple system configuration.

You need these components to set up one MCCAT system:

- MCCAT switch
- MCCAT user station (optional)
- MCCAT Computer Interface Modules (MCIMs) or MCUTP cables

---

## MCCAT Switch

The MCCAT switch provides ports for connecting computers and a set of keyboard, mouse, and monitor. There are two types of MCCAT switches: one-user and two-user types. The difference between one-user and two-user types is that the two-user type additionally provides *USB* ports for connecting the USB keyboard and mouse, and an *RJ-45* port for connecting an MCCAT user station.

- ONE-USER type

Only one user can gain access to the "one-user" MCCAT switch and connected computers at a time.

There are two models: MCCAT18 and MCCAT116.

- TWO-USER type

Two users can gain access to the "two-user" MCCAT switch and connected computers at a time.

There are two models: MCCAT28 and MCCAT216.

---

*Note: This User Guide focuses on TWO-USER type. For information on "one-user" MCCAT switches, see the Quick Setup Guide that comes with them, or download the MCCAT18/116 User Guide from Raritan's*

**Firmware and Documentation webpage**

*(<http://www.raritan.com/support/firmware-and-documentation/>).*

---

---

### **MCCAT User Station**

An MCCAT user station connects a set of keyboard, mouse and monitor to a compatible KVM switch. After connecting the user station to the MCCAT switch, two users can access the system at a time.

There is only one MCCAT user station model: MCCAT-UST.

---

### **MCCAT Computer Interface Module (MCIM)**

The MCIM transmits keyboard, mouse and video signals between the connected computer and the MCCAT switch. One computer requires one MCIM only. There are two types of them.

- USB type

MCIM-USB comes with an HD15 VGA connector and a USB connector.

- PS/2 type

MCIM-PS2 comes with an HD15 VGA connector, a PS/2 keyboard connector, and a PS/2 mouse connector.

---

### **MCUTP Cable**

One MCUTP cable is a combination of Computer Interface Module (CIM) and Cat5 UTP cable so you can use it in place of the MCIM.

The MCUTP cable is *not* compatible with Windows 98 operating system. Use MCIM for computers running Windows 98.

There are three types of them.

- USB type

This type comes with an HD15 VGA connector, a USB connector and an RJ-45 connector.

Model	Cable length
MCUTP06-USB	0.6 meter (2 feet)
MCUTP20-USB	2 meters (6.5 feet)
MCUTP40-USB	4 meters (13 feet)
MCUTP60-USB	6 meters (20 feet)

- PS/2 type

This type comes with an HD15 VGA connector, a PS/2 keyboard connector, a PS/2 mouse connector and an RJ-45 connector.

Model	Cable length
MCUTP06-PS2	0.6 meter (2 feet)
MCUTP20-PS2	2 meters (6.5 feet)
MCUTP40-PS2	4 meters (13 feet)
MCUTP60-PS2	6 meters (20 feet)

- Sun USB type

This type comes with an HD15 VGA connector, a Sun USB connector and an RJ-45 connector.

Model	Cable length
MCUTP06-SUSB	0.6 meter (2 feet)
MCUTP20-SUSB	2 meters (6.5 feet)
MCUTP40-SUSB	4 meters (13 feet)
MCUTP60-SUSB	6 meters (20 feet)

---

## Product Photos

**MCCAT28 (Front and Rear View)**



**MCCAT216 (Front and Rear View)**



**MCCAT-UST (Front and Rear View)**



### MCUTP20-PS2 Cable



### MCUTP20-USB or MCUTP20-SUSB Cable



---

## Product Features

---

### MCCAT Switch

- A user can control multiple computers per unit. The number of computers that can be controlled varies depending on the model you purchased:
  - **MCCAT28** can control a maximum of 8 computers
  - **MCCAT216** can control a maximum of 16 computers

- Support a maximum of 256 computers if cascading MCCAT switches
- Support two-user operation
- Support the PC Share mode
- Multi-platform support, including MS-DOS, Windows 2000/2003/NT/XP/Vista, Macintosh OS9/OSX, Linux (Red Hat, Novell Suse), SCO Unix, and Sun Solaris
- Support IBM, Dell, HP, and Sun servers
- Support the video resolution up to 1600x1200
- Enable users to be located away from the computers up to:
  - 100 feet (30.48 meters) for video resolution at 1600x1200
  - 150 feet (45.72 meters) for video resolution at 1280x1024 or below
- Interconnect with computers via standard Cat5 UTP cables
- Feature simple system control and management with the OSD interface
- With the “keep-alive” technology, you can add, remove, and hot-swap components without interruption to the computers
- The **Scan** function enables the system to automatically cycle through all channels, and updates the channel status
- The **Skip** function enables the system to bypass "inactive" channels

---

*Note: An "active" channel is the channel port where the MCCAT switch detects the connection of a powered MCIM or MCUTP cable. An "inactive" channel is the opposite. See **What are Active and Inactive Channels** (on page 30) for more information.*

---

- The **Login** mechanism prevents unauthorized access to the MCCAT switch and connected computers
- Easy firmware upgrade via a standard RS-232 serial cable
- Channel buttons on the front panel enable fast access to computers
- Support a standard USB or PS/2 keyboard and mouse

---

#### **MCCAT User Station**

- Interconnect with a compatible KVM switch via a standard Cat5 UTP cable
- Support a standard USB or PS/2 keyboard and mouse
- Easy firmware upgrade via a standard RS-232 serial cable

---

### **Package Contents**

Based on the package you purchased, your package may or may not contain the MCCAT user station. If you purchase *MCCAT28-UST* or *MCCAT216-UST*, the package surely contains the user station.

---

### MCCAT Switch

- MCCAT switch x 1
- Power cord x 1
- Rackmount kit x 1 (including brackets and associated screws)
- Quick Setup Guide x 1
- Warranty card x 1

---

### MCCAT User Station (Optional)

- MCCAT user station x 1
- Power adapter x 1
- Quick Setup Guide x 1
- Warranty card x 1

---

## Structure Diagrams

This section provides a brief introduction to the components on the front and rear sides of the MCCAT switch and user station.

---

### MCCAT Switch

#### Front View

Push buttons on the front panel work only for the user who operates the keyboard, mouse and monitor directly connected to the MCCAT switch. Do *not* use front panel buttons when operating the keyboard and mouse connected to the MCCAT user station.

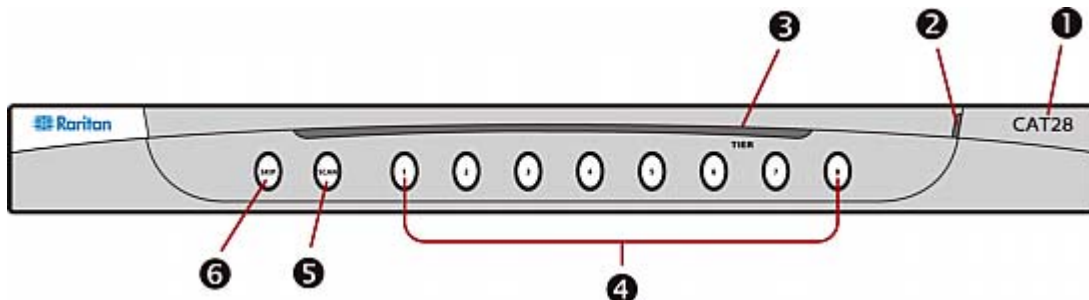

❶	Model name	<ul style="list-style-type: none"> <li>• CAT28: The device is MCCAT28.</li> <li>• CAT216: The device is MCCAT216.</li> </ul>
❷	Power LED	Indicates whether the device is turned on. When lit, it is turned ON. When off, either there is no power supply or the device is turned OFF.
❸	TIER LED	Shows the device's tier status.

		<ul style="list-style-type: none"> <li>• <i>Off</i>: The MCCAT switch is programmed as the first-tier device, that is, the base switch. This is the factory default.</li> <li>• <i>Green</i>: The MCCAT switch is programmed as the second-tier device. For instructions, see <b>STEP (A): Programme an MCCAT Switch as a Second-Tier Device</b> (on page 60).</li> </ul>
④	Channel buttons	<p>Enable immediate access to the computers connected to corresponding channel ports. Besides, each channel button can show the channel status by changing LED colors as explained below.</p> <ul style="list-style-type: none"> <li>• <i>Off</i>: The channel is inactive. See <b>Inactive Channels</b> (on page 30).</li> <li>• <i>Orange</i>: The channel is active. See <b>Active Channels</b> (on page 30).</li> <li>• <i>Green</i>: A user is accessing the channel, which may be either active or inactive.</li> </ul> <hr/> <p><i>Tip: If channel LEDs do not display the channel status properly, you can refresh the channel statuses. See <b>Refreshing Channel Statuses</b> (on page 43).</i></p>
⑤	SCAN button	<p>Toggles the <b>Scan</b> function on or off.</p> <p>When the <b>Scan</b> function is ON, the button's LED is lit, and the system automatically cycles through all channels until the function is turned off.</p>
⑥	SKIP button	<p>Toggles the <b>Skip</b> function on or off.</p> <p>When the <b>Skip</b> function is ON, the button's LED is lit, and the system skips "inactive" channels and accesses "active" ones only. See <b>What are Active and Inactive Channels</b> (on page 30).</p>

Rear View

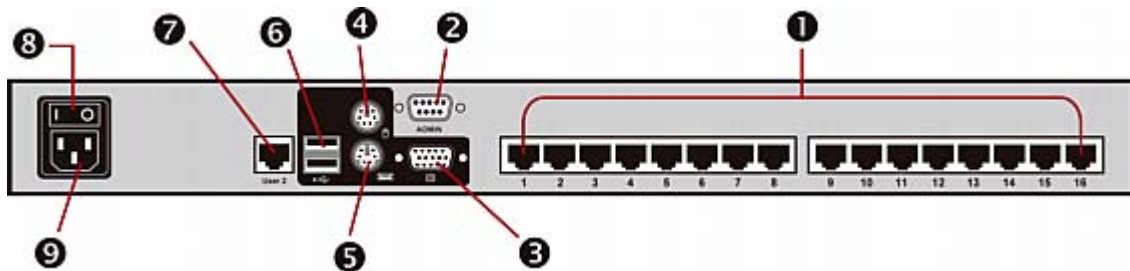

①	Channel ports	Connect computers. Depending on the model you purchased, the device may have 8 or 16 channel ports.
②	Admin port	Connects a computer for upgrading the firmware.
③	VGA port	Connects a VGA monitor.
④	PS/2 mouse port	Connects a PS/2 mouse.



5	PS/2 keyboard port	Connects a PS/2 keyboard.
6	USB K/M ports	Connect a USB keyboard and mouse.
7	User 2 port	Connects an optional MCCAT user station.
8	Power switch	Toggles the power on or off.
9	Power socket	Connects a power cord.

Warning: Do NOT connect both PS/2 and USB keyboards or both PS/2 and USB mice simultaneously. If you do so, only the USB keyboard and/or mouse work properly.

### MCCAT User Station

One MCCAT user station can connect a set of keyboard, mouse and monitor to any of these devices:

- A compatible KVM switch, including MCCAT28, MCCAT216, TMCAT1728, or TMCAT17216.
- A computer. See **User Station Direct Mode** (on page 71) for more information.

### Front View



1	Power LED	Indicates whether the device is turned on. When lit, it is turned ON. When off, there is no power supply to the device.
---	-----------	--

### Rear View

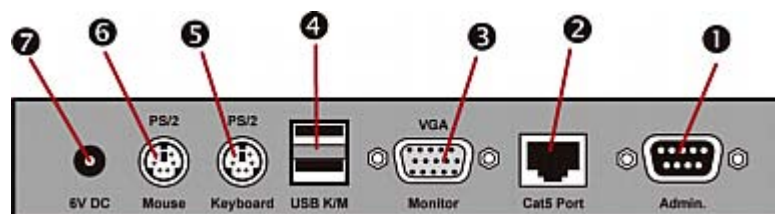

1	Admin port	Connects a computer for upgrading the firmware.
2	Cat5 port	Connects a compatible KVM switch or a computer.

③	VGA port	Connects a VGA monitor.
④	USB K/M ports	Connect a USB keyboard and mouse.
⑤	PS/2 keyboard port	Connects a PS/2 keyboard.
⑥	PS/2 mouse port	Connects a PS/2 mouse.
⑦	Power jack	Connects a power adapter.

Warning: Do NOT connect both PS/2 and USB keyboards or both PS/2 and USB mice simultaneously. If you do so, only the USB keyboard and/or mouse work properly.

## Chapter 2 Quick Start

This chapter addresses installation steps for setting up a basic MCCAT system and basic procedure for accessing connected computers. For advanced OSD operations or hardware installation, see **Advanced Operation** (on page 34), **System Settings** (on page 44), and **Two-Tier System** (on page 59).

### In This Chapter

Rack-Mounting MCCAT Switches .....	11
Basic Installation.....	15
Connecting a User Station (Optional).....	19
Login .....	22
Accessing a Computer or Channel.....	23
Logout.....	25

---

### Rack-Mounting MCCAT Switches

MCCAT switches can be mounted in 1U (1.75", 4.4cm) of vertical space in a standard 19" equipment rack. To rack-mount an MCCAT switch, use the brackets and screws (Bracket Assy of P2-HUBPAC) that came with the device. You can mount the MCCAT switch facing the front of the rack or the rear.

---

### Attaching the Cable-Support Bar (Optional)

If there are any concerns regarding the cabling weight, you can install the cable-support bar between two rackmount brackets to bear the weight of cables connected to the rear of MCCAT switch. Depending on how you rack-mount the MCCAT switch, the position to attach the cable-support bar varies:

- If the MCCAT switch's front panel will face the front of the rack, fasten the cable-support bar to the L-shaped holes far from the ears of the rackmount brackets.
- If the MCCAT switch's front panel will face the rear of the rack, fasten the cable-support bar to the L-shaped holes close to the ears of the rackmount brackets.

► **To attach the cable-support bar**

1. Insert one end of the cable-support bar into the L-shaped hole on a rackmount bracket, with the bar's concave slot facing the top of the upper L-shaped hole or the bottom of the lower L-shaped hole.

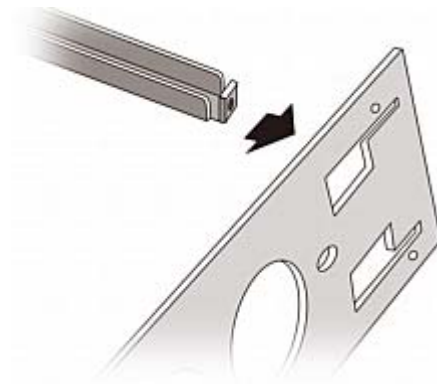

2. Move the cable-support bar upward or downward to make the concave slot hold the top edge of the upper L-shaped hole or the bottom edge of the lower L-shaped hole.
3. Slide the bar horizontally along the edge of the L-shaped hole until the hole on the end of the bar is aligned with the threaded hole above or below the L-shaped hole.

- Secure the cable-support bar with one of the included cap screws.

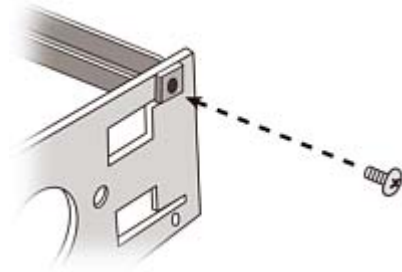

- Repeat Steps 1 to 4 to secure the other end of the cable-support bar to the other rackmount bracket.

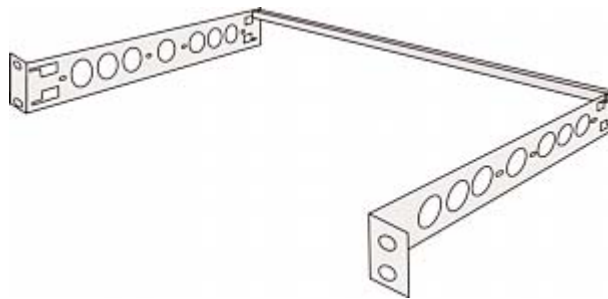

After securing the cable-support bar, you can attach the bracket assembly to the MCCAT switch and mount the device in your rack. See **Forward Mount** (on page 13) or **Rear Mount** (on page 14).

► **Before attaching the bracket assembly to the MCCAT switch**

If you attach the cable-support bar to the upper L-shaped holes, turn the bracket assembly upside down.

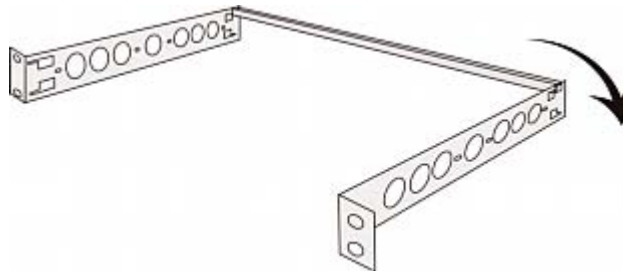



---

### Forward Mount

► **To rack-mount the MCCAT switch with the front panel facing the front of the rack**

- Let the MCCAT switch's front panel and the bracket's "ear" face toward you.

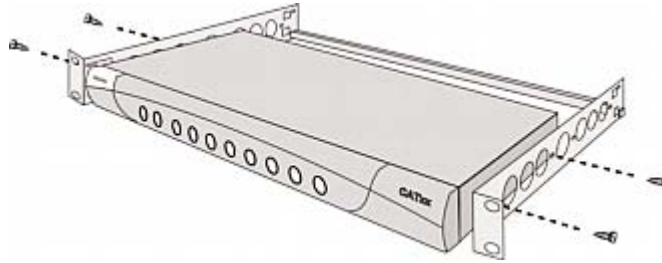
2. Align two oval-shaped holes close to the ear of the bracket with two threaded holes on one side of the MCCAT switch.
3. Secure the bracket to the MCCAT switch with two of the included screws.
4. Repeat Steps 1 to 3 for securing the other bracket to the other side of the MCCAT switch.
5. Mount the entire assembly in the rack, and secure the brackets' ears to the rack's front rails with your own screws, bolts, cage nuts, and so on.



---

### Rear Mount

► **To rack-mount the MCCAT switch with the front panel facing the rear of the rack**

1. Let the MCCAT switch's rear panel and the bracket's "ear" face toward you.
2. Align two oval-shaped holes far from the ear of the bracket with two threaded holes on one side of the MCCAT switch.
3. Secure the bracket to the MCCAT switch with two of the included screws.
4. Repeat Steps 1 to 3 for securing the other bracket to the other side of the MCCAT switch.
5. Mount the entire assembly in the rack, and secure the brackets' ears to the rack's front rails with your own screws, bolts, cage nuts, and so on.



---

## Basic Installation

---

### Preparing Requisite Items

Collect these components or devices before making the connection.

- MCIMs or MCUTP cables (one per computer)
  - If using MCIMs, Cat5 UTP cables are required

The MCUTP cable is *not* compatible with Windows 98 operating system. Use MCIM for computers running Windows 98.

- At least one standard PS/2 or USB keyboard
- At least one standard PS/2 or USB mouse
- At least one standard monitor with HD15 VGA connector

---

*Note: If the computer is a Sun server, you must prepare the Sun USB MCUTP cable or DCIM-USB G2 instead of MCIM.*

---

### Making the Connection

1. Turn OFF all devices, including the MCCAT switch and computers.
2. Connect one MCIM or MCUTP cable to the computer.
  - *If using MCIM-USB or USB MCUTP cable:*
    - a. Plug the MCIM or MCUTP's USB connector into one of the computer's available USB ports.
    - b. Plug the MCIM or MCUTP's video connector into the computer's VGA port.

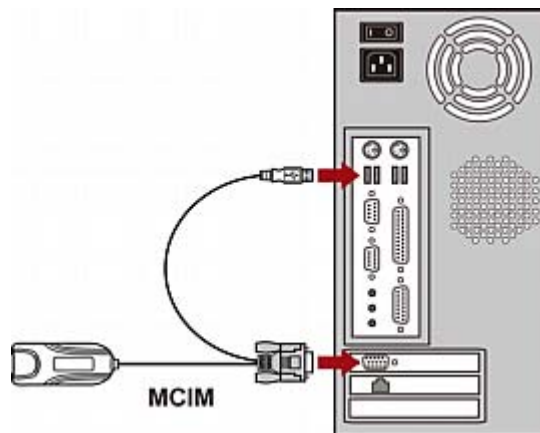

- OR -

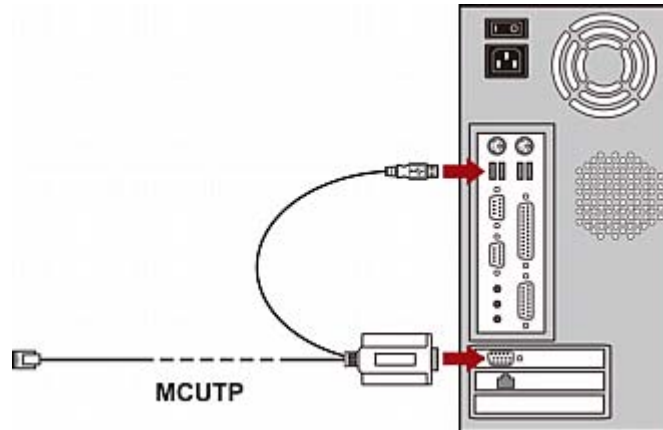

- *If using MCIM-PS2 or PS/2 MCUTP cable:*
  - a. Plug the MCIM or MCUTP's PS/2 mouse connector into the computer's PS/2 mouse port.
  - b. Plug the MCIM or MCUTP's PS/2 keyboard connector into the computer's PS/2 keyboard port.
  - c. Plug the MCIM or MCUTP's video connector into the computer's VGA port.

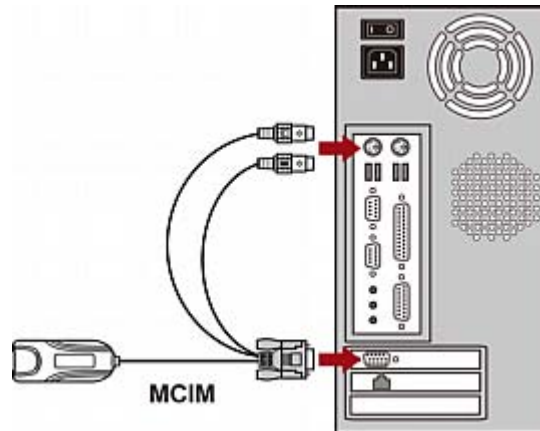



- OR -

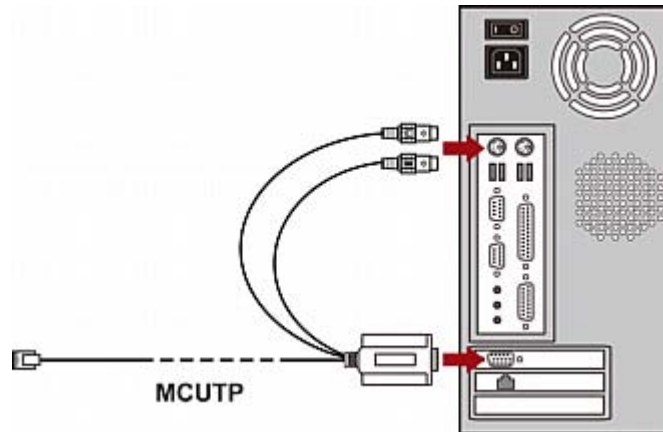

- *If using the Sun USB MCUTP cable:*
  - a. Plug the MCUTP's Sun USB connector into one of the available USB ports on the Sun server.
  - b. Plug the MCUTP's video connector into the VGA port on the Sun server.

---

*Note: See **Supporting Sun Servers** (on page 41) in the User Guide for more information.*

---

3. Connect the computer to the MCCAT switch.
  - *If using the MCIM:*
    - a. Plug one end of a Cat5 UTP cable into the RJ-45 port of the MCIM being connected with the computer.
    - b. Plug the other end of the Cat5 UTP cable into one of the channel ports on the MCCAT switch.

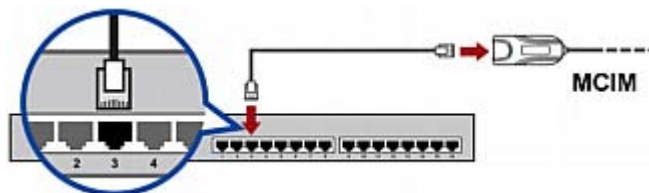

- *If using the MCUTP cable:*

- Plug the MCUTP cable's RJ-45 connector into one of the channel ports on the MCCAT switch.

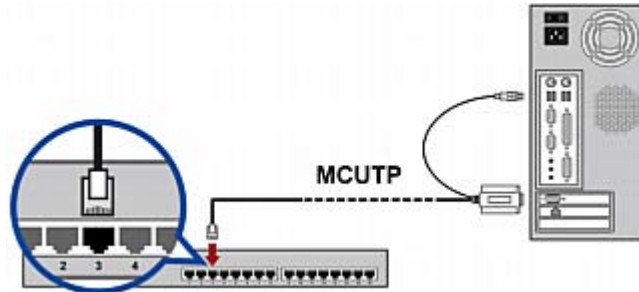

4. Repeat Steps 2 to 3 to connect more computers.
5. (Optional) Connect the MCCAT user station to the **User 2** port on the MCCAT switch via a standard Cat5 UTP cable. For more information, see the *Quick Setup Guide* shipped with the user station or **Connecting a User Station (Optional)** (on page 19) in the User Guide.

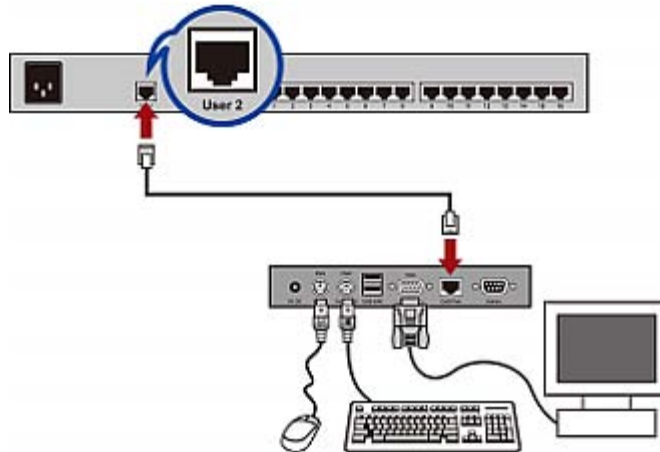

---

*Tip: The MCCAT switch is compatible with the Paragon II enhanced user station, **P2-EUST** (see "P2-EUST User Station" on page 89). If you have P2-EUST, you can connect it, instead of the MCCAT user station, to the MCCAT switch.*

---

6. Connect a keyboard, mouse and monitor to the MCCAT switch.
  - a. Plug the mouse's connector into the PS/2 or USB port on the MCCAT switch.
  - b. Plug the keyboard's connector into the PS/2 or USB port on the MCCAT switch.

- c. Plug the monitor's VGA connector into the VGA port on the MCCAT switch.

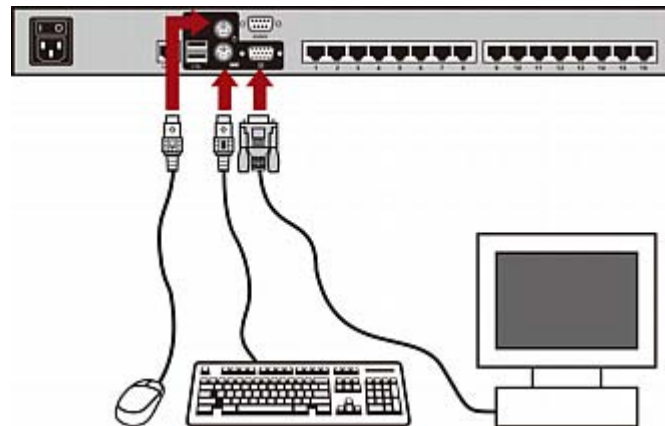

---

*Warning: Do NOT connect both PS/2 and USB keyboards or both PS/2 and USB mice simultaneously. If you do so, only the USB keyboard and/or mouse work properly.*

---

7. Connect an appropriate power cord to every device in the MCCAT system.
8. Turn on connected computers and monitors.
9. Turn on the MCCAT switch.

---

### Connecting a User Station (Optional)

You can connect the MCCAT user station to any compatible KVM switch, such as the "two-user" MCCAT switch or TMCAT17 series, to increase the number of users who can access the KVM switch and computers.

1. Connect the PS/2 or USB keyboard and mouse to the user station.
  - a. Plug the mouse's connector into the PS/2 or USB port on the user station.

- b. Plug the keyboard's connector into the PS/2 or USB port on the user station.



---

*Warning: Do NOT connect both PS/2 and USB keyboards or both PS/2 and USB mice simultaneously. If you do so, only the USB keyboard and/or mouse work properly.*

---

2. Connect the VGA monitor to the user station.

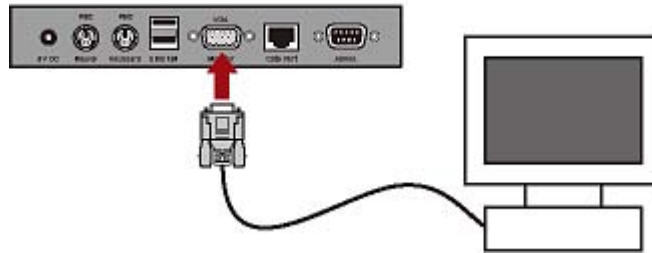

3. Connect the user station to the KVM switch via a standard Cat5 UTP cable.
  - a. Plug one end of the Cat5 cable into the **Cat5 Port** of the user station.

- b. Plug the other end of the cable into the **User 2** port of the KVM switch.

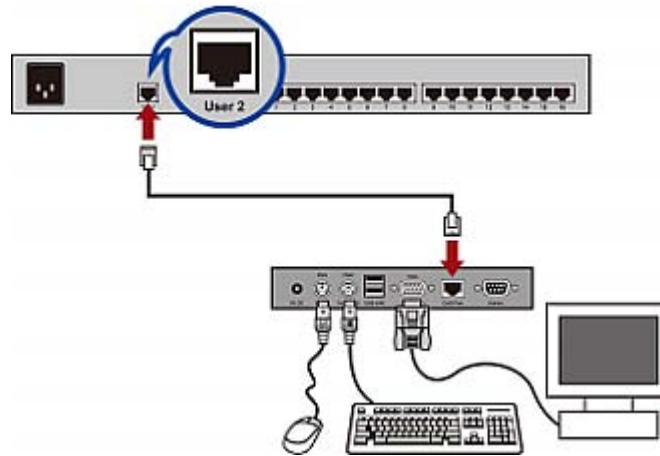

4. Connect the power adapter to the user station.
  - a. Plug one end of the power adapter into the power jack of the user station.
  - b. Plug the other end of the power adapter into the appropriate power outlet.
5. Turn on the connected monitor.

After finishing the installation and turning on all devices, you can use the keyboard, mouse, and monitor connected with the user station to access computers connected to the KVM switch.

---

*Tip: The MCCAT switch is compatible with the Paragon II enhanced user station, **P2-EUST** (see "P2-EUST User Station" on page 89). If you have P2-EUST, you can connect it, instead of the MCCAT user station, to the MCCAT switch.*

---

---

## Login

The login mechanism prevents unauthorized users from accessing the system or changing settings. To access any computer, you may log in with any user account. To configure the system settings on the Administration Menu, you must log in with the administrator account.

---

*Note: <XXX> shown in the diagrams represents the model name, which varies according to the product you purchased.*

---

► **To log in to the MCCAT system:**

1. The Login box appears on the screen after turning ON the MCCAT system.

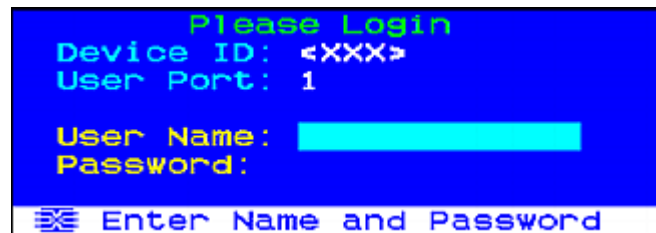

2. Type your user name and password. For example, if you are the administrator, the user name is "admin," and the default password is "raritan."
  - a. Type admin in the User Name field, and press Enter.
  - b. Type raritan in the Password field, and press Enter. The password is case sensitive.

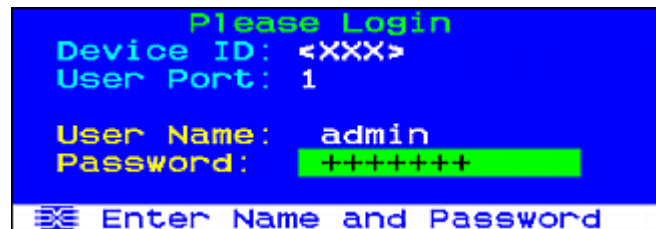

3. The Selection Menu appears, indicating your login is successful.

Selection Menu				
<XXX>	Page			1/2
No	Ch. ID	Name		Scn
1	01			05
2	02			05
3	03			05
4	04			05
5	05			05
6	06			05
7	07			05
8	08			05

Page FKey Ent Esc  
 Scr1Lock | Scan | skip | NCS

**Important:** It is strongly recommended to change the default password for the security of your MCCAT system. For more information, see *Changing Passwords* (on page 47) in the User Guide.

## Accessing a Computer or Channel

After login, you can select any channel to view, and control the computer connected to the channel. Depending on which set of keyboard, mouse and monitor you use, there may be one method or two for channel selection. The keyboard, mouse and monitor are hereafter called "input/output devices."

- If operating the input/output devices connected directly to the MCCAT switch, you can use:
  - **Selection Menu** of the On-Screen Display (OSD), or
  - **Channel buttons** on the front panel

To access any channel for the first time after logging in to the system, you must use the Selection Menu.

*Note: In a two-tier system, front panel buttons on the "second-tier" MCCAT switches are all disabled so only OSD is available on the second-tier devices.*

- If operating the input/output devices connected to the MCCAT user station, you can use:
  - **Selection Menu** of the OSD

## Using the Selection Menu

The first OSD menu that appears after login is the Selection Menu, which does not show any channel name by default until you assign them.

Selection Menu			
<XXX>			
			Page 1 / 2
No	Ch. ID	Name	Scn
1	01		05
2	02		05
3	03		05
4	04		05
5	05		05
6	06		05
7	07		05
8	08		05

Navigation: [Grid] [Box] Page FKey Ent Esc  
 Scr1Lock | Scan | Skip | NCS

### ► To select a channel on the Selection Menu:

1. If you do not find the channel on the current page, press Page Down or Page Up to go to the next or previous page.
2. Press ↓ or ↑ to move the highlight bar to the channel you want to select.

*Tip: You can press the corresponding number shown in the No column for that channel to quickly highlight it.*

3. Press Enter.

The Selection Menu disappears. The video of the accessed computer appears on the screen. You can control the computer with the keyboard and mouse.

MCCAT switches do not support real-time channel detection. Do NOT disconnect the current computer and reconnect a different one to the channel you are accessing, or you may have mouse or keyboard input issues with that channel. When this occurs, re-select the channel on the Selection Menu to solve the problem.

### ► To select a different channel on the Selection Menu:

1. If you do not see the OSD on the screen, press the hot key twice QUICKLY to activate it. The default hot key is Scroll Lock.
2. Highlight another channel and press Enter.

For more information on the Selection Menu, see **Selection Menu** (on page 28) in the User Guide.



---

## Using Channel Buttons

Front panel buttons start to function after you access any channel using the Selection Menu. You can use front panel buttons as long as you operate the input/output devices connected directly to the MCCAT switch.

---

*Note: In a two-tier system, front panel buttons on the "second-tier" MCCAT switches are all disabled so only OSD is available on the second-tier devices.*

---

### ► To select the channel by pressing channel buttons

1. If you see the OSD on the screen, press Esc until it disappears.
2. Press the button for the channel that you want to access.
  - MCCAT28 channel buttons



- MCCAT216 channel buttons



The video of the accessed computer appears on the screen. You can control the computer with the keyboard and mouse.

---

## Logout

After completing your tasks in the MCCAT system, you should log out to prevent unauthorized people from accessing the system.

### ► To log out of the MCCAT system:

1. If you do not see the OSD on the screen, press the hot key twice QUICKLY to activate it. The default hot key is Scroll Lock.
2. Press F9.

The Login box appears, indicating that you have successfully logged out.

## Chapter 3 Introduction to the OSD Interface

The OSD interface offers these functions:

- Channel selection
- System configuration
- Displaying product information

### In This Chapter

OSD Layout.....	26
Activating the OSD.....	29
Variations of Highlight Colors.....	29
Channel Colors .....	29
OSD Operation Keys .....	31

## OSD Layout

This section indicates the main elements displayed on the OSD images.

### Login Box

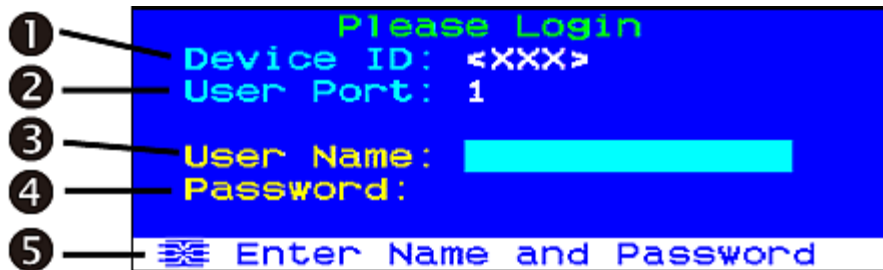

❶	Device ID	The name of the MCCAT switch that you are operating. Factory default is the model name. You can customize this name. See <b>Renaming the MCCAT Switch</b> (on page 46) for more information.
❷	User Port	Current input/output devices* via which you access the MCCAT switch and connected computers. <ul style="list-style-type: none"> <li>• 1 refers to the input/output devices directly connected with the MCCAT switch.</li> <li>• 2 refers to the input/output devices connected with the MCCAT user station, which is connected to the <b>User 2</b> port of the MCCAT switch.</li> </ul>
❸	User Name	The field where you type the administrator or user account for login.
❹	Password	The field where you type the password for login.
❺	Message bar	The location that displays messages or prompts relevant with current OSD screen.

\* Input/output devices refer to the keyboard, mouse, and monitor.

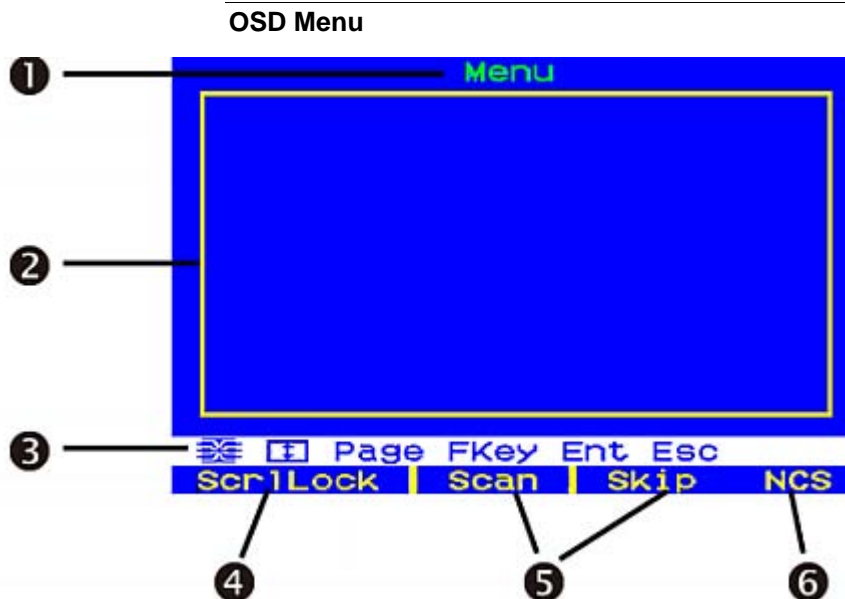

❶	Menu title	The title of the current menu or submenu.
❷	Data display area	The area that displays information or settings of the current menu or submenu.
❸	Message bar	The location that displays messages or prompts relevant with current OSD screen.
❹	Current hot key	The hot key that activates the OSD. The default is Scroll Lock (ScrLock).
❺	Status of the Scan and Skip functions	If the Scan or Skip function is turned ON, the color turns yellow. Otherwise, the color is black.
❻	Status of N, C, and S	N represents NumLock, C represents Caps Lock, and S is Scroll Lock. If any function is turned ON, its color turns yellow. Otherwise, the color is black.

### Selection Menu

In addition to the OSD menu's main layout, the Selection Menu provides additional elements, which are helpful for locating and selecting channels.

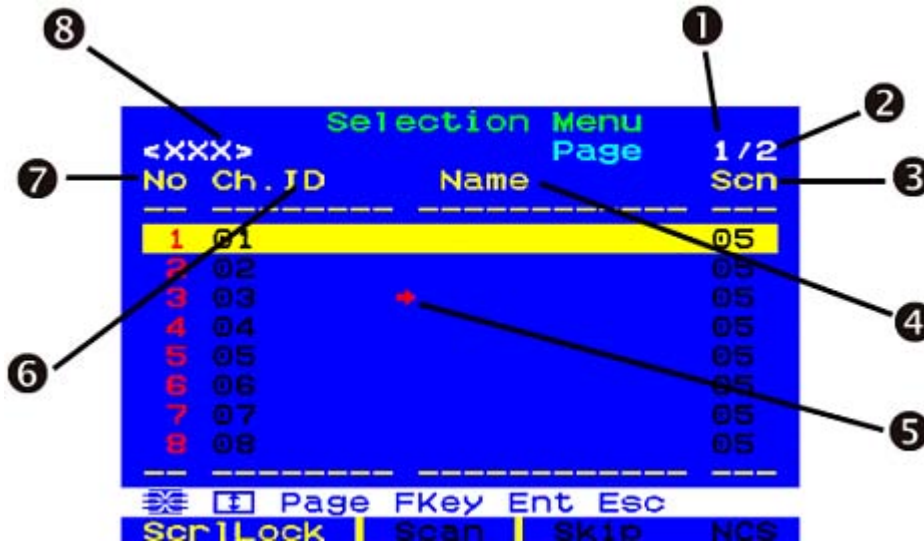

①	Current page number	The number of current page.
②	Total of pages	The total number of pages.
③	Scn	The scan rate in seconds for each channel. If the channel is connected to a second-tier KVM switch, it shows dashes (- -) instead.
④	Name	The channel name that you have specified, if any.
⑤	Channel selection indicator	If you are accessing any channel, the red arrow appears on the OSD to indicate the channel you are accessing.
⑥	Ch. ID	The channel port number. If sorting the Selection Menu by channel name, the system precedes each channel port number with the MCCAT switch's name.
⑦	No	The number that you can press for quickly selecting the desired channel.
⑧	Device name	The name of current MCCAT switch whose channels are displayed on the screen. Factory default is the model name.

*Tip: The Selection Menu is sorted by channel number by default, but you can sort it based on channel names. See **Switching the Channel Sorting** (on page 35).*

---

## Activating the OSD

The OSD disappears after you access any channel. To access a different channel or change the system settings, you must activate the OSD.

► **To activate the OSD:**

- Press the hot key (default: Scroll Lock) twice QUICKLY.

You can assign a hot key other than Scroll Lock. See **Changing the Hot Key** (on page 48).

---

## Variations of Highlight Colors

The highlight bar can change its colors to indicate different statuses when you are changing settings on specific menus or submenus.

1. The highlight color is **yellow** in the beginning, indicating that you *cannot* make changes to the current field.
2. Press Enter, and the highlight color turns **green** or **light blue**, indicating that you *can* make changes to the current field.
3. After making changes, press Enter or Esc, and the highlight color turns **yellow** again, indicating that you *cannot* make changes to the current field.

The difference between pressing Enter and Esc is:

- If pressing Enter, you confirm to retain the changes made to the field.
- If pressing Esc, you abandon the changes made to the field, and the field returns to the original value or option.

---

## Channel Colors

Different channel colors on the Selection Menu represent different channel statuses. Channel colors vary according to these criteria:

- The channels are active or inactive. See **What are Active and Inactive Channels** (on page 30).
- The channels are being accessed or not.

---

*Note: The MCCAT system does not auto-detect and update the channel status in real time. To ensure you get the latest channel status, perform the channel refreshing. See **Refreshing Channel Statuses** (on page 43).*

---

---

### What are Active and Inactive Channels

One of the factors that affect channel colors is the active/inactive status of a channel, which varies based on the power status of the connected CIM or MCUTP cable. This section explains the definition of active and inactive channels.

#### Active Channels

The MCCAT switch recognizes a channel as being active when it detects that the channel port is connected to a powered CIM or MCUTP cable. A CIM or MCUTP cable is powered when the computer or device that it connects supplies power to it via the PS/2 keyboard or USB port.

A CIM or MCUTP cable always receives power in this scenario:

- The CIM or MCUTP's PS/2 keyboard or USB connector is plugged into a computer or device that is turned ON.

The CIM or MCUTP cable may or may not be powered when the computer is turned OFF, which varies depending on the computer's design.

---

*Tip: You can check the CIM's LED to find whether it is powered. If it is powered, the LED is flashing. Otherwise, the LED light is off continuously.*

---

#### Inactive Channels

The MCCAT switch recognizes a channel as being inactive when it does *not* detect that the channel port is connected to a powered CIM or MCUTP cable, which involves these scenarios:

- No CIM or MCUTP cable is connected to the channel port.
- A CIM or MCUTP cable is connected to the channel port, but it is unpowered as its PS/2 keyboard or USB connector is not plugged into any computer or device.

The CIM or MCUTP cable may or may not be powered when the computer is turned OFF, which varies depending on the computer's design.

---

### Channel Colors and Statuses

This table indicates channel statuses and corresponding channel colors.

Color	Channel status
Black	This is an inactive channel.
Green	<p>This is an active channel that you can access.</p> <ul style="list-style-type: none"> <li>In the Private mode, active channels are green as long as the other user is NOT accessing them.</li> <li>In the PC Share mode, every active channel is green no matter the other user is accessing them or not.</li> </ul>
Red	<p>This is a channel, either active or inactive, which you <i>cannot</i> access.</p> <ul style="list-style-type: none"> <li>In the Private mode, a channel is red when the other user is accessing it. If the channel is connected to a second-tier device, all channels of that second-tier device are red, too.</li> <li>In the PC Share mode, a channel is red only when it is connected to a second-tier device that is being accessed by the other user. In addition, all channels of the accessed second-tier device are red.</li> </ul>

---

### OSD Operation Keys

When you have logged in to the system, and the OSD is displayed on the screen, you can use these keys to navigate through the OSD menus, change settings, and so on.

► **To switch between menus:**

Key	Function
F1	Switches to the Help menu
F2	Switches to the Selection Menu
F5*	Switches to the Administration Menu

\* Only the administrator has the permission to access the **Administration Menu** (see "System Settings" on page 44).

► **To switch between pages:**

Key	Function
Page Up	Switches to the previous page

Key	Function
Page Down	Switches to the next page
Home	Switches to the first page
End	Switches to the last page

▶ **To select fields or channels:**

Key	Function
Tab*	Moves forward
Shift+Tab*	Moves backward
Arrow keys (↑, ↓, ←, →)	Move the highlight bar
Enter	Confirms the selection of the field or channel

\* The key or key combination is not applicable to the Selection Menu.

▶ **To change the values or options of the selected fields:**

Key	Function
Arrow keys (↑, ↓, ←, →)	Switch between available options, or adjust the numeric values of certain fields after the highlight color turns green
Enter	Confirms the current selection or the changes you make
Esc	Cancel the current selection or the changes you make

▶ **To exit from the menu or system:**

Key	Function
Esc	Exits from the current menu or submenu
F9	Logs you out of the MCCAT system

▶ **Others:**

Key	Function
F6	Toggles the <b>Scan</b> function on or off
F7	Toggles the <b>Skip</b> function on or off
S	Saves the changes you make to the current menu or submenu



<b>Key</b>	<b>Function</b>
G	Accesses the Channel Configuration submenu of the second-tier devices in a <i>two-tier</i> system

# Chapter 4    Advanced Operation

This chapter introduces more features of MCCAT switches, including front panel operation and OSD operation.

You must log in to the system before being able to perform any function. For login instructions, see **Login** (on page 22).

**If your MCCAT system is a two-tier system, make sure you follow these guidelines:**

- All of the second-tier MCCAT switches have been programmed as the second-tier devices.

If not, the operation or configuration you perform at the MCCAT base switch applies to the base switch alone instead of the whole system. For programming instructions, see **STEP (A): Programme an MCCAT Switch as a Second-Tier Device** (on page 60).

- Always perform the operation or configuration at the MCCAT base switch (the first tier).

## In This Chapter

Switching the Channel Sorting .....	35
Cycling Through Channels.....	36
Accessing Active Channels Only .....	38
Sharing the Computer .....	40
Activating the Help Menu .....	41
Supporting Sun Servers.....	41
Refreshing Channel Statuses .....	43

## Switching the Channel Sorting

The Selection Menu is sorted by channel number by default, but you can sort it based on channel names.

► **To switch the channel sorting:**

- Press F12 when the Selection Menu is displayed.

The Selection Menu switches from the current sorting to the other sorting.

### Sorting by channel number

Selection Menu				
<XXX>	Page			1/2
No	Ch. ID	Name	Scn	
1	01	Win Vista	05	
2	02	Win XP	05	
3	03	Win 2000	05	
4	04	Linux	05	
5	05	Unix	05	
6	06	Sun	05	
7	07	HP	05	
8	08	Email server	05	

Page FKey Ent Esc  
Scr1Lock | Scan | Skip | NCS

### Sorting by channel name

Selection Menu by Name		
Name	Ch. ID	Page
Email server	<XXX>.08	1/2
HP	<XXX>.07	
Linux	<XXX>.04	
Sun	<XXX>.06	
Unix	<XXX>.05	
Win 2000	<XXX>.03	
Win Vista	<XXX>.01	
Win XP	<XXX>.02	

Page PCName FKey Ent Esc  
Scr1Lock | Scan | Skip | NCS

*Tip: When the Selection Menu is sorted by channel name, you can type initial character(s) of the desired channel's name to quickly locate the names beginning with matching character(s).*

---

## Cycling Through Channels

You can turn on the Scan function to have the MCCAT system automatically display the video of every computer one by one on the screen. If the system scans a channel port where a second-tier device is connected, it will scan all channels of the second-tier device first before proceeding with the next channels on the base switch.

The channel status will be updated after channel scanning so you can perform channel scanning whenever you need to retrieve the latest channel status.

---

*Note: If you want to update the channel status shown by front panel LEDs, the Scan function must be turned on using the input/output devices connected directly to the MCCAT switch.*

---

Depending on which set of input/output devices you are using, there may be two methods or one to turn on the Scan function.

If operating the input/output devices connected directly to the MCCAT switch, you can press:

- The SCAN button on the front panel, or
- The function key F6 when the OSD is on the screen

If operating the input/output devices connected to the MCCAT switch via the MCCAT user station, you can press:

- The function key F6 when the OSD is on the screen

---

*Tip: You can customize the scan rate. See **Changing the Scan Rate** (on page 46) for more information.*

---

Channel buttons are disabled during channel scanning. To use the channel button for accessing any channel, turn OFF the Scan function first.

---

### Using the SCAN Button

Front panel buttons start to function after you access any channel using the Selection Menu. You can use front panel buttons as long as you operate the input/output devices connected directly to the MCCAT switch.

---

*Note: In a two-tier system, front panel buttons on the "second-tier" MCCAT switches are all disabled so only OSD is available on the second-tier devices.*

---

► **To turn on the Scan function:**

1. If you see the OSD on the screen, press Esc until it disappears.

2. Press the SCAN button on the front panel, and the button is lit.



The system displays the video of each channel one by one on the screen. When a channel is being scanned, its channel name and number will show up for seconds.

---

*Tip: You may shorten the overall scanning time by scanning "active" channels only. For more information, see **Accessing Active Channels Only** (on page 38).*

---

► **To turn off the Scan function:**

1. If you see the OSD on the screen, press Esc until it disappears.
2. Press the SCAN button again, and the button light turns off.

The system stops scanning, and the screen displays the video of the last scanned channel.

---

### Using the F6 Function Key

► **To turn on the Scan function:**

1. If you do not see the OSD on the screen, press the hot key twice QUICKLY to activate it. The default hot key is Scroll Lock.
2. Press F6. The Scan status at the bottom of the OSD turns yellow.
3. Press Esc to quit the OSD.

The system displays the video of each channel one by one on the screen. When a channel is being scanned, its channel name and number will show up for seconds.

---

*Tip: You may shorten the overall scanning time by scanning "active" channels only. For more information, see **Accessing Active Channels Only** (on page 38).*

---

► **To turn off the Scan function:**

1. If you do not see the OSD on the screen, press the hot key twice QUICKLY to activate it. The default hot key is Scroll Lock.
2. Press F6 again. The Scan status at the bottom of the OSD turns black.

---

## Accessing Active Channels Only

To avoid accessing any inactive channels when scanning or manually selecting channels, turn on the Skip function.

The system behaves differently with the Scan function being turned on or off.

- **When the Scan function is ON**

The system scans active channels only by skipping all inactive channels. See **What are Active and Inactive Channels** (on page 30).

- **When the Scan function is OFF**

The system allows you to select active channels only, which are displayed in green on the Selection Menu.

Or, if you press the channel button for any inactive channel, the system accesses the next active channel that is available instead of the channel you choose.

Depending on which set of input/output devices you are using, there may be two methods or one to turn on the Skip function.

If operating the input/output devices connected directly to the MCCAT switch, you can press:

- The SKIP button on the front panel, or
- The function key F7 when the OSD is on the screen

If operating the input/output devices connected to the MCCAT switch via the MCCAT user station, you can press:

- The function key F7 when the OSD is on the screen

---

### Using the SKIP Button

Front panel buttons start to function after you access any channel using the Selection Menu. You can use front panel buttons as long as you operate the input/output devices connected directly to the MCCAT switch.

*Note: In a two-tier system, front panel buttons on the "second-tier" MCCAT switches are all disabled so only OSD is available on the second-tier devices.*

---

► **To turn on the Skip function:**

1. If you see the OSD on the screen, press Esc until it disappears.

2. Press the SKIP button on the front panel, and the button is lit.



► **To turn off the Skip function:**

1. If you see the OSD on the screen, press Esc until it disappears.
2. Press the SKIP button again, and the button light turns off.

---

**Using the F7 Function Key**

► **To turn on the Skip function:**

1. If you do not see the OSD on the screen, press the hot key twice QUICKLY to activate it. The default hot key is Scroll Lock.
2. Press F7. The Skip status at the bottom of the OSD turns yellow.
3. Press Esc to quit the OSD.

► **To turn off the Skip function:**

1. If you do not see the OSD on the screen, press the hot key twice QUICKLY to activate it. The default hot key is Scroll Lock.
2. Press F7 again. The Skip status at the bottom of the OSD turns black.

---

## Sharing the Computer

The product provides two operation modes: Private and PC Share mode. Private mode allows only one user to access a channel at a time, but PC Share mode allows multiple users to access the same channel simultaneously.

PC Share mode functions in one of these scenarios:

- The administrator has turned on the **PC Share mode** (see "Changing the Operation Mode" on page 49).
- You are accessing the channels of the "second-tier" devices.

---

*Note: The user from the base switch always shares second-tier channels with the "local" user, who operates the keyboard and mouse directly connected to the second-tier device. This is because the PC Share mode is automatically applied to all second-tier devices regardless of the operation mode selected at the base switch.*

---

### ▶ To share the computer:

1. Ensure that the PC Share mode is activated or applied.
2. Now you can share the same channel with the other user. Depending on the channel access sequence, you may or may not be able to control the computer.
  - If you access the channel earlier than the other user—you can control the computer, and the other user can only view the video.
  - If you access the channel later than the other user—the other user can control the computer, and you can only view the video.

### ▶ To release the computer control:

If you are the controlling user, you can release the computer control by doing one of these:

- Exit from the channel by selecting another channel or logging out
- Both of you and the other user who accesses the same channel stop using the keyboard and mouse for 5 seconds

After the computer control is released, any user who first generates the keystroke or moves the mouse gains the control of the computer.

---

*Note: It is normal that initial keyboard or mouse inputs are not processed by the computer when the computer control is being shifted to one of the users.*

---



---

## Activating the Help Menu

When the OSD is displayed on the screen, you can view its help at any time. The Help menu shows:

- OSD function keys and their brief descriptions
- Product information, including:
  - Firmware version
  - Hardware version
  - FPGA version
  - Serial number

```

Help/Information
F1 Help / ESC Exit
F2 Channel Selection
F5 Administrative Functions
F6 Toggle Scan On/Off
F7 Toggle Skip On/Off
F9 Logout
F12 Sort by Channel/Name

Firmware Ver: 2A16
Hardware Ver: 01
FPGA Ver: 011
Serial Number: AG62222345
FKey Esc
ScrollLock | Scan | Skip | NCS

```

► **To access the Help menu:**

1. If you do not see the OSD on the screen, press the hot key twice QUICKLY to activate it. The default hot key is Scroll Lock.
2. Press F1.

---

## Supporting Sun Servers

The product supports Sun servers. To connect Sun servers, you must use the CIM or MCUTP cable designed for Sun servers, that is, DCIM-USB G2 or MCUTPxx-SUSB, where xx represents the cable length.

► **To connect Sun servers via the MCUTPxx-SUSB cables:**

- See Steps 2 to 3 in the section: **Connecting the Equipment** (see "Making the Connection" on page 15).

► **To connect Sun servers via DCIM-USB G2:**

1. Move the slide switch on the back of the DCIM-USB G2 to the right side so that the character "S" is visible. "S" refers to the Sun server.

2. Connect the DCIM-USB G2 to the Sun server.
  - Plug the CIM's USB connector into one of available USB ports on the Sun server.
  - Plug the CIM's video connector into the VGA port on the Sun server.
3. Connect the Sun server to one of the channel ports on the MCCAT switch via a standard Cat5 UTP cable.
  - Plug one end of the Cat5 UTP cable into the RJ-45 port of the CIM being connected with the Sun server.
4. Plug the other end of the Cat5 UTP cable into one of the channel ports on the MCCAT switch.

Raritan recommends that you use a Sun USB keyboard directly connected to the MCCAT switch to control Sun servers so you can take advantage of special Sun keys like Props or Front. If these keys do not function properly, see **Emulating Special Sun Keys** (on page 42) for the alternative solution.

---

### Emulating Special Sun Keys

Special Sun keys, such as the Again and Props keys, are unavailable on regular keyboards. When using a non-Sun keyboard or these keys on a Sun keyboard do not work properly, the MCCAT switch allows you to emulate them through combination keys.

#### When to Emulate Sun Keys

You emulate special Sun keys when they are either unavailable or do not function properly.

If connecting a Sun keyboard to the MCCAT switch, these special Sun keys do NOT function when its keyboard signals pass through the **User 2** port of any switch.

You must use combination keys to emulate special keys when:

- You are using a regular keyboard to control Sun servers.
- The Sun keyboard you use is connected to the MCCAT user station, which transmits keyboard signals through the **User 2** port of the MCCAT switch.
- You are accessing a Sun server that is connected to the "second-tier device," which communicates with the base switch through the **User 2** port.

**Combination Keys Table**

This table lists special Sun keys and corresponding combination keys.

Sun key	Combination keys
Again	Ctrl + Alt + F2
Props	Ctrl + Alt + F3
Undo	Ctrl + Alt + F4
Front	Ctrl + Alt + F5
Copy	Ctrl + Alt + F6
Open	Ctrl + Alt + F7
Paste	Ctrl + Alt + F8
Find	Ctrl + Alt + F9
Cut	Ctrl + Alt + F10
Help	Ctrl + Alt + F11
Mute	Ctrl + Alt + F12
Compose	Ctrl + Alt + * (the asterisk symbol on the keypad)
Volume +	Ctrl + Alt + + (the plus symbol on the keypad)
Volume -	Ctrl + Alt + - (the minus symbol on the keypad)
Stop	Pause/Break

---

**Refreshing Channel Statuses**

The MCCAT system does not automatically update channel statuses if you change the hardware configuration, such as channel swapping, turning on or off any computer. To get the up-to-date channel statuses, do one of these:

- If many channels are impacted:
  - Power cycle the MCCAT system by turning it OFF and then ON, or
  - Perform the Scan function until all channels are scanned at least once. See **Cycling Through Channels** (on page 36).
- If few channels are impacted, you can access impacted channels one by one to update their channel statuses. See **Accessing a Computer or Channel** (on page 23).

# Chapter 5 System Settings

You can adjust the MCCAT system settings on the Administration Menu. Only the administrator has the permission to access this menu so you must log in using the administrator account, which comprises the following user name and password by default.

- User name: *admin*
- Password: *raritan*

**If your MCCAT system is a two-tier system, make sure you follow these guidelines:**

- All of the second-tier MCCAT switches have been programmed as the second-tier devices.

If not, the operation or configuration you perform at the MCCAT base switch applies to the base switch alone instead of the whole system. For programming instructions, see **STEP (A): Programme an MCCAT Switch as a Second-Tier Device** (on page 60).

- Always perform the operation or configuration at the MCCAT base switch (the first tier).

### In This Chapter

Assigning or Modifying Channel Names .....	45
Changing the Scan Rate .....	46
Renaming the MCCAT Switch .....	46
Changing Passwords .....	47
Changing the Hot Key .....	48
Changing the Operation Mode .....	49
Setting Up the Green Mode .....	50
Setting Up the Logoff Timeout Function .....	51
Hiding the Login Box .....	52
Managing User Accounts .....	53
Setting Up the Channel ID Display Function .....	55
Adjusting the OSD Menu Position .....	57
Resetting System Settings .....	57

---

## Assigning or Modifying Channel Names

By default there are no channel names assigned to any connected devices on the Selection Menu. Only channel port numbers are available. It is not easy to identify the computers or devices without appropriate channel names, so you should specify a channel name for each connected computer or device.

► **To specify or change channel names:**

1. If you do not see the OSD on the screen, press the hot key twice QUICKLY to activate it. The default hot key is Scroll Lock.
2. Press F5. The Administration Menu appears.
3. Select the third submenu, Channel Configuration. To select the submenu, either press 3, or press ↓ to highlight it and then press Enter. The Channel Configuration submenu appears.
4. If you do not find the channel on the current page, press Page Down or Page Up to go to the next or previous page.
5. Press ↓ or ↑ to highlight the channel name you want to modify, and press Enter. The yellow highlight color turns light blue.
6. Type a new name up to twelve characters. The highlight color turns green when you type.
7. Press Enter to confirm the new name. The highlight color turns yellow again.
8. Repeat Steps 4 to 7 to modify more channel names.
9. Press S to save the changes or Esc to quit the current menu or submenu.
  - If pressing Esc, the message “Save the changes [Y/N/ESC]” appears on the message bar. Press Y to save the changes, N to abort the changes, or Esc to return to the current menu or submenu.

---

*Note: To name the channels of the second-tier devices in a two-tier system, see **Setting Up the Second-Tier Channels** (on page 65) for information.*

---

---

## Changing the Scan Rate

When the Scan function is ON, the system scans each channel for 5 seconds by default. You can change the scan rate of each channel. Valid range is 5 to 24 seconds.

► **To change scan rates:**

1. If you do not see the OSD on the screen, press the hot key twice QUICKLY to activate it. The default hot key is Scroll Lock.
2. Press F5. The Administration Menu appears.
3. Select the third submenu, Channel Configuration. To select the submenu, either press 3, or press ↓ to highlight it and then press Enter. The Channel Configuration submenu appears.
4. If you do not find the channel on the current page, press Page Down or Page Up to go to the next or previous page.
5. Press ↓ or ↑ to highlight the channel whose scan rate you want to modify.
6. Press Tab or → to select the field in the Scn column, and press Enter. The highlight color turns green.
7. Press any arrow key to adjust the numeric value by 1, or type two numeric digits. Then press Enter. The highlight color turns yellow.
8. Repeat Steps 4 to 7 to change the scan rates for other channels.
9. Press S to save the changes or Esc to quit the current menu or submenu.
  - If pressing Esc, the message “Save the changes [Y/N/ESC]” appears on the message bar. Press Y to save the changes, N to abort the changes, or Esc to return to the current menu or submenu.

---

## Renaming the MCCAT Switch

The default device name of each MCCAT switch is its model name. You can customize the name for better identification of the device.

---

*Note: The device name does not accept special characters, such as \*, &, %, <>, and so on.*

---

► **To change the name of the MCCAT switch:**

1. If you do not see the OSD on the screen, press the hot key twice QUICKLY to activate it. The default hot key is Scroll Lock.
2. Press F5. The Administration Menu appears.

3. Select the first submenu, System Configuration. To select the submenu, either press 1, or press ↓ or ↑ to highlight it and then press Enter.
4. Press Tab or Shift+Tab to highlight the Device ID field, and press Enter. The highlight color turns green.
5. Type the new name up to 12 characters, and press Enter. The highlight color turns yellow.
6. Press S to save the changes or Esc to quit the current menu or submenu.
  - If pressing Esc, the message "Save the changes [Y/N/ESC]" appears on the message bar. Press Y to save the changes, N to abort the changes, or Esc to return to the current menu or submenu.

---

*Note: In a two-tier system, you name the base switch by following the procedure in this section, but name each second-tier MCCAT switch by naming corresponding channels on the base switch. See **Assigning or Modifying Channel Names** (on page 45).*

---

## Changing Passwords

It is strongly recommended to change the default password for the security of your MCCAT system.

The default password for the administrator account (Admin) is "raritan" (all lower case), and there are no passwords for any user accounts by default.

### ► To change passwords:

1. If you do not see the OSD on the screen, press the hot key twice QUICKLY to activate it. The default hot key is Scroll Lock.
2. Press F5. The Administration Menu appears.
3. Select the second submenu, User Configuration. To select the submenu, either press 2, or press ↓ or ↑ to highlight it and then press Enter. The User Configuration submenu appears.
4. Press ↓ or ↑ to highlight the user account whose password you want to change.
5. Press P. The message "Enter old password" appears on the message bar.
6. Type the current password, and press Enter. Note the password is case sensitive.
  - If there are no passwords, press Enter or Esc.
7. The message "Enter new password" appears on the message bar. Type a new password up to eight characters, and press Enter.

8. The message "Confirm password" appears on the message bar. Re-type the new password, and press Enter.
  - When the message "Password Changed" appears on the message bar, the password is changed successfully.
9. Repeat Steps 4 to 8 to change the passwords for other user accounts.

---

**Important: Write down your new passwords and keep them in a safe place. If you forget your passwords, there are no ways to retrieve them. You must delete that user account and re-create a new one.**

---

## Changing the Hot Key

You use the hot key to activate the OSD when it is not displayed on the screen. The default hot key is Scroll Lock. You can assign a key other than Scroll Lock as the hot key. Available options include Scroll Lock, Left Alt, Left Shift, Caps Lock, and Num Lock.

► **To change the hot key setting:**

1. If you do not see the OSD on the screen, press the hot key twice QUICKLY to activate it. The default hot key is Scroll Lock.
2. Press F5. The Administration Menu appears.
3. Select the first submenu, System Configuration. To select the submenu, either press 1, or press ↓ or ↑ to highlight it and then press Enter.
4. Press Tab or Shift+Tab to highlight the Hotkey field, and press Enter. The highlight color turns green.
5. Press any arrow key to switch between available options, and press Enter to confirm your selection. The highlight color turns yellow.
6. Press S to save the changes or Esc to quit the current menu or submenu.
  - If pressing Esc, the message "Save the changes [Y/N/ESC]" appears on the message bar. Press Y to save the changes, N to abort the changes, or Esc to return to the current menu or submenu.

---

**Important: In a two-tier system, you must log in to the base switch and every second-tier MCCAT switch using the keyboard directly connected to them, to change the hot key assignment one by one.**

---



---

## Changing the Operation Mode

There are two operation modes in the MCCAT system: Private and PC Share modes.

- Private mode: When a user is accessing any channel, the other user cannot access the same channel unless the first user exits from that channel.
- PC Share mode: Multiple users can access the same channel simultaneously. Only the user who first presses any key on the keyboard or moves the mouse can control the computer, and the other user can only view the video. See **Sharing the Computer** (on page 40) for more information.

► **To change the operation mode:**

1. If you do not see the OSD on the screen, press the hot key twice QUICKLY to activate it. The default hot key is Scroll Lock.
2. Press F5. The Administration Menu appears.
3. Select the first submenu, System Configuration. To select the submenu, either press 1, or press ↓ or ↑ to highlight it and then press Enter.
4. Press Tab or Shift+Tab to highlight the Operation Mode field, and press Enter. The highlight color turns green.
5. Press any arrow key to switch between available options, and press Enter to confirm your selection. The highlight color turns yellow.
6. Press S to save the changes or Esc to quit the current menu or submenu.
  - If pressing Esc, the message “Save the changes [Y/N/ESC]” appears on the message bar. Press Y to save the changes, N to abort the changes, or Esc to return to the current menu or submenu.

---

**Important: Even though you have turned on the PC Share mode at the base switch, you CANNOT share the same channels of the second-tier devices with the other user who also logs in to the base switch. For more information, see *Limitations of the Two-Tier System* (on page 67).**

---

---

## Setting Up the Green Mode

Green Mode is the power-saving mode for the monitor. When the MCCAT system does NOT detect any keystrokes or mouse activities for a preset period of time after you access a channel, the system enters the Green Mode, and the screen becomes blank. You can turn on or off the function, or change the length of time for which the keyboard and mouse must be idle before the system enters the Green Mode.

► **To turn on the Green Mode and adjust the timing:**

1. If you do not see the OSD on the screen, press the hot key twice QUICKLY to activate it. The default hot key is Scroll Lock.
2. Press F5. The Administration Menu appears.
3. Select the first submenu, System Configuration. To select the submenu, either press 1, or press ↓ or ↑ to highlight it and then press Enter.
4. Press Tab or Shift+Tab to highlight the Green Mode field, and press Enter. The highlight color turns green.
5. Press any arrow key to select the option, On, and press Enter. The highlight color turns yellow.
6. Change the timing setting if necessary.
  - a. Press Tab or → to select the timing field to the right, and press Enter. The highlight color turns green.
  - b. Press any arrow key to adjust the numeric value by 1, or type two numeric digits. Then press Enter. The highlight color turns yellow.
7. Press S to save the changes or Esc to quit the current menu or submenu.
  - If pressing Esc, the message “Save the changes [Y/N/ESC]” appears on the message bar. Press Y to save the changes, N to abort the changes, or Esc to return to the current menu or submenu.

---

*Note: When the monitor enters the power-saving mode, you can press any key or move the mouse to wake it up.*

---

► **To turn off the Green Mode:**

1. Select the Green Mode field by following Steps 1 to 4 described above.
2. Press any arrow key to select the option, Off, and press Enter. The highlight color turns yellow.
3. Press S to save the changes or Esc to quit the current menu or submenu.

- If pressing Esc, the message “Save the changes [Y/N/ESC]” appears on the message bar. Press Y to save the changes, N to abort the changes, or Esc to return to the current menu or submenu.

---

## Setting Up the Logoff Timeout Function

You can turn on the Logoff Timeout feature so when a logged-in user stops using the keyboard and mouse for a preset period of time, the MCCAT system automatically logs out of that user.

### ▶ To turn on the Logoff Timeout function and adjust the timing:

1. If you do not see the OSD on the screen, press the hot key twice QUICKLY to activate it. The default hot key is Scroll Lock.
2. Press F5. The Administration Menu appears.
3. Select the first submenu, System Configuration. To select the submenu, either press 1, or press **↓** or **↑** to highlight it and then press Enter.
4. Press Tab or Shift+Tab to highlight the Logoff Timeout field, and press Enter. The highlight color turns green.
5. Press any arrow key to select the option, On, and press Enter. The highlight color turns yellow.
6. Change the timing setting if necessary. The default is 5 minutes.
  - a. Press Tab or **→** to select the timing field to the right, and press Enter. The highlight color turns green.
  - b. Press any arrow key to adjust the numeric value by 1, or type two numeric digits. Then press Enter. The highlight color turns yellow.
7. Press S to save the changes or Esc to quit the current menu or submenu.
  - If pressing Esc, the message “Save the changes [Y/N/ESC]” appears on the message bar. Press Y to save the changes, N to abort the changes, or Esc to return to the current menu or submenu.

### ▶ To turn off the Logoff Timeout function:

1. Select the Logoff Timeout field by following Steps 1 to 4 described above.
2. Press any arrow key to select the option, Off, and press Enter. The highlight color turns yellow.
3. Press S to save the changes or Esc to quit the current menu or submenu.

- If pressing Esc, the message “Save the changes [Y/N/ESC]” appears on the message bar. Press Y to save the changes, N to abort the changes, or Esc to return to the current menu or submenu.

---

## Hiding the Login Box

The Login box is continuously displayed on the screen by default. You can have the system automatically hide the Login box when no one makes any attempts to log in for a preset period of time. The function is called Login Blank, and it helps save the monitor's power during the idle time.

► **To turn on the Login Blank function and adjust the timing:**

1. If you do not see the OSD on the screen, press the hot key twice QUICKLY to activate it. The default hot key is Scroll Lock.
2. Press F5. The Administration Menu appears.
3. Select the first submenu, System Configuration. To select the submenu, either press 1, or press ↓ or ↑ to highlight it and then press Enter.
4. Press Tab or Shift+Tab to highlight the Login Blank field, and press Enter. The highlight color turns green.
5. Press any arrow key to select the option, On, and press Enter. The highlight color turns yellow.
6. Change the timing setting if necessary.
  - a. Press Tab or → to select the timing field to the right, and press Enter. The highlight color turns green.
  - b. Press any arrow key to adjust the numeric value by 1, or type two numeric digits. Then press Enter. The highlight color turns yellow.
7. Press S to save the changes or Esc to quit the current menu or submenu.
  - If pressing Esc, the message “Save the changes [Y/N/ESC]” appears on the message bar. Press Y to save the changes, N to abort the changes, or Esc to return to the current menu or submenu.

---

*Note: When the monitor enters the power-saving mode, you can press any key or move the mouse to wake it up.*

---

► **To turn off the Login Blank function:**

1. Select the Login Blank field by following Steps 1 to 4 described above.
2. Press any arrow key to select the option, Off, and press Enter. The highlight color turns yellow.

3. Press S to save the changes or Esc to quit the current menu or submenu.
  - If pressing Esc, the message “Save the changes [Y/N/ESC]” appears on the message bar. Press Y to save the changes, N to abort the changes, or Esc to return to the current menu or submenu.

---

## Managing User Accounts

The product provides one administrator account and seven user accounts by default. They are Admin and User01 through User07. You cannot remove or rename the administrator account (Admin), but you can rename, remove or add user accounts.

---

### Renaming User Accounts

You can rename existing user accounts.

► **To rename a user account:**

1. If you do not see the OSD on the screen, press the hot key twice QUICKLY to activate it. The default hot key is Scroll Lock.
2. Press F5. The Administration Menu appears.
3. Select the second submenu, User Configuration. To select the submenu, either press 2, or press ↓ or ↑ to highlight it and then press Enter. The User Configuration submenu appears.
4. Press ↓ or ↑ to highlight the user account you want to rename, and press Enter. The highlight color turns light blue.
5. Type a new name up to eight characters, and press Enter. The highlight color turns yellow.
6. Press S to save the changes or Esc to quit the current menu or submenu.
  - If pressing Esc, the message “Save the changes [Y/N/ESC]” appears on the message bar. Press Y to save the changes, N to abort the changes, or Esc to return to the current menu or submenu.

---

### Adding User Accounts

You can have up to 127 user accounts by creating new accounts.

► **To add new user accounts:**

1. If you do not see the OSD on the screen, press the hot key twice QUICKLY to activate it. The default hot key is Scroll Lock.
2. Press F5. The Administration Menu appears.

3. Select the second submenu, User Configuration. To select the submenu, either press 2, or press ↓ or ↑ to highlight it and then press Enter. The User Configuration submenu appears.
4. Press Insert. The system creates a new user account with the name syntax—User<xx>, where <xx> is the sequential number, following the last existing user account.
5. The message "Save the changes [Y/N/ESC]" appears on the message bar. Press Y to confirm the addition, or N or Esc to cancel the addition.
6. Repeat Steps 4 to 5 to add more user accounts.
7. Press Esc to quit the current submenu.

The system does not assign any password to a new user account by default. To assign any password, see **Changing Passwords** (on page 47). To change the user name, see **Renaming User Accounts** (on page 53).

---

### Deleting User Accounts

You can remove obsolete user accounts when necessary.

► **To delete user accounts:**

1. If you do not see the OSD on the screen, press the hot key twice QUICKLY to activate it. The default hot key is Scroll Lock.
2. Press F5. The Administration Menu appears.
3. Select the second submenu, User Configuration. To select the submenu, either press 2, or press ↓ or ↑ to highlight it and then press Enter. The User Configuration submenu appears.
4. Press ↓ or ↑ to highlight the user account you want to delete, and press Delete.
5. The message "Delete this user [Y/N/ESC]" appears on the message bar. Press Y to confirm the deletion, or N or Esc to cancel the deletion.
6. Repeat Steps 4 to 5 to delete more user accounts.
7. Press Esc to quit the submenu.

## Setting Up the Channel ID Display Function

Whenever you access any channel to which a computer or any non-KVM-switch device is connected, a line of text comprising the device name, channel number and name appears on the screen for seconds. The line is the "ID" of the accessed channel.

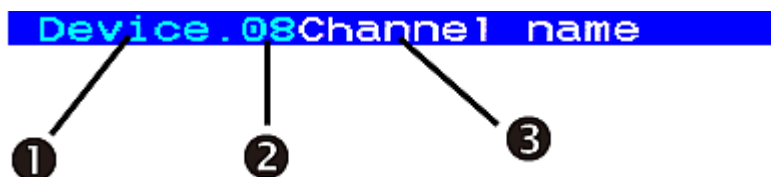

❶	Current KVM switch's name.
❷	Channel number.
❸	The text in white is the channel name. If no channel name has been assigned to the accessed channel, this part is blank.

You can determine whether the system displays the channel ID, how long and even where on the screen it displays the ID by changing the OSD settings.

### Setting Up the ID Display Function

► **To turn on the ID display function and adjust the display timing:**

1. If you do not see the OSD on the screen, press the hot key twice QUICKLY to activate it. The default hot key is Scroll Lock.
2. Press F5. The Administration Menu appears.
3. Select the first submenu, System Configuration. To select the submenu, either press 1, or press ↓ or ↑ to highlight it and then press Enter.
4. Press Tab or Shift+Tab to highlight the ID Display field, and press Enter. The highlight color turns green.
5. Press any arrow key to select the option, On, and press Enter. The highlight color turns yellow.
6. Change the ID Display timing if necessary.
  - a. Press Tab or → to select the timing field to the right, and press Enter. The highlight color turns green.
  - b. Press any arrow key to adjust the numeric value by 1, or type two numeric digits. Then press Enter. The highlight color turns yellow.

- To display the ID continuously on the screen, select "- -" (dashes).
7. Press S to save the changes or Esc to quit the current menu or submenu.
    - If pressing Esc, the message "Save the changes [Y/N/ESC]" appears on the message bar. Press Y to save the changes, N to abort the changes, or Esc to return to the current menu or submenu.

► **To turn off the ID display function:**

1. Select the ID Display field by following Steps 1 to 4 described above.
2. Press any arrow key to select the option, Off, and press Enter. The highlight color turns yellow.
3. Press S to save the changes or Esc to quit the current menu or submenu.
  - If pressing Esc, the message "Save the changes [Y/N/ESC]" appears on the message bar. Press Y to save the changes, N to abort the changes, or Esc to return to the current menu or submenu.

---

### Adjusting the ID Display Position

► **To adjust the channel ID position:**

1. If you do not see the OSD on the screen, press the hot key twice QUICKLY to activate it. The default hot key is Scroll Lock.
2. Press F5. The Administration Menu appears.
3. Select the first submenu, System Configuration. To select the submenu, either press 1, or press ↓ or ↑ to highlight it and then press Enter.
4. Press Tab or Shift+Tab to highlight the "ID" item in the Display Position field, and press Enter.
5. The sample ID bar appears on the screen.



Now move it to the position you prefer by pressing the arrow keys.

6. Press Enter to confirm the new position.
7. Press S to save the changes or Esc to quit the current menu or submenu.
  - If pressing Esc, the message "Save the changes [Y/N/ESC]" appears on the message bar. Press Y to save the changes, N to abort the changes, or Esc to return to the current menu or submenu.



---

## Adjusting the OSD Menu Position

You may move the OSD menu to the position you prefer on the screen.

► **To adjust the OSD menu position:**

1. If you do not see the OSD on the screen, press the hot key twice QUICKLY to activate it. The default hot key is Scroll Lock.
2. Press F5. The Administration Menu appears.
3. Select the first submenu, System Configuration. To select the submenu, either press 1, or press ↓ or ↑ to highlight it and then press Enter.
4. Press Tab or Shift+Tab to highlight the "Menu" item in the Display Position field, and press Enter. The highlight color turns green.
5. Now move the OSD menu to the position you prefer by pressing the arrow keys.
6. Press Enter to confirm the new position. The highlight color turns yellow.
7. Press S to save the changes or Esc to quit the current menu or submenu.
  - If pressing Esc, the message "Save the changes [Y/N/ESC]" appears on the message bar. Press Y to save the changes, N to abort the changes, or Esc to return to the current menu or submenu.

---

## Resetting System Settings

You may clear current system settings and have all settings return to factory defaults. These settings are:

- All settings involved on the Administration Menu, including:
  - System Configuration
  - User Configuration
  - Channel Configuration
- The tier programming of the MCCAT switch:
  - The device will be programmed back as the base switch (the first-tier device) after the reset

Resetting the device does not require you to log in as the administrator.

► **To reset system settings:**

1. Turn OFF the MCCAT switch.

2. Press and hold down the channel number 3 button on the front panel, and turn ON the MCCAT switch simultaneously.
3. Continue to hold down the channel number 3 button until you hear the beep sound.

In a two-tier system, reset the base switch only. Do not reset the second-tier devices unless necessary. If you reset second-tier devices, ensure that you **re-programme them** (see "STEP (A): Programme an MCCAT Switch as a Second-Tier Device" on page 60).

# Chapter 6 Two-Tier System

You can connect multiple MCCAT switches to organize a two-tier system, expanding the number of available channels. Different models can be mixed in the system. If the system completely comprises the 16-channel-port models, the number of connected computers can be expanded up to 256 computers.

## In This Chapter

Overview.....	59
Establishing a Two-Tier System.....	60
Setting Up the Second-Tier Channels.....	65
Accessing the Second-Tier Channels.....	66
Returning to the Base Switch's OSD.....	67

---

## Overview

When you connect one MCCAT switch or more to a MCCAT switch, you are organizing a "two-tier" system.

All MCCAT switches connected to the same MCCAT switch are the SECOND-TIER devices, and the MCCAT switch that connects these second-tier devices is the "base switch," belonging to the FIRST TIER.

You can connect computers to any channel ports available in the system, including channel ports on the base switch.

---

*Note: In a two-tier system, all front panel buttons on the second-tier MCCAT switches are automatically disabled.*

---

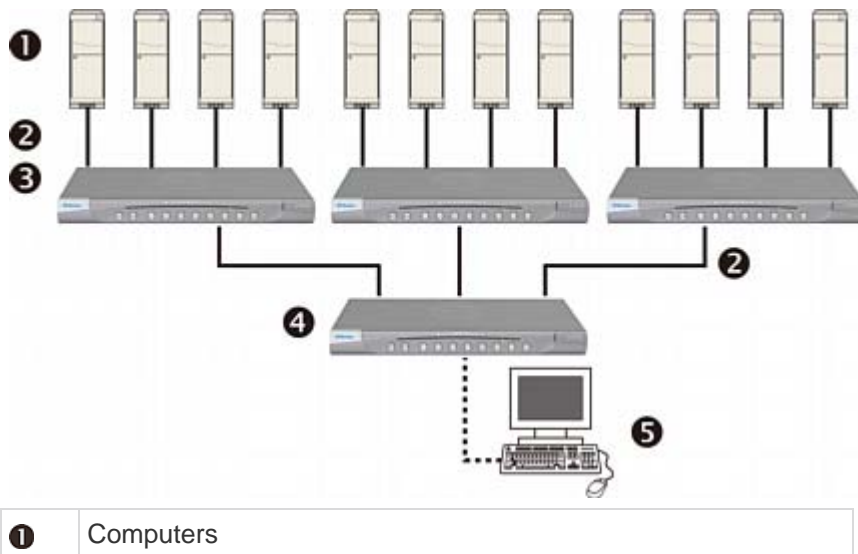

②	Cat5 UTP cables
③	Second-tier MCCAT switches
④	MCCAT base switch (the first tier)
⑤	Input/output devices (keyboard, mouse, and monitor)

---

## Establishing a Two-Tier System

Basically, there are five major steps to establish a two-tier system:

- STEP (A): Programme an MCCAT switch as a second-tier device
- STEP (B): Connect the second-tier MCCAT switch to the base switch
- STEP (C): Connect input/output devices to the base switch
- STEP (D): Specify the type of the second-tier device on the OSD
- STEP (E): Connect computers to the MCCAT system

---

### STEP (A): Programme an MCCAT Switch as a Second-Tier Device

Each MCCAT switch is programmed as a base switch by default. To establish a two-tier system, you must change the default programming of the MCCAT switches that you want to set as the second-tier devices.

► **To programme the MCCAT switch as a second-tier device:**

1. Turn OFF the MCCAT switch.
2. Press and hold down the channel number 2 button on the front panel, and turn ON the MCCAT switch simultaneously.
3. Continue holding down the channel number 2 button until you hear the beep sound.
  - The TIER LED will be lit continuously, indicating that the MCCAT switch has been programmed as a second-tier device.
4. Repeat Steps 1 to 3 to change the programming of more MCCAT switches.

---

*Note: To programme a second-tier device back as the base switch, follow the same procedure in this section but press the channel number 1 button instead. When the TIER LED's light is off, the device is programmed back as a base switch.*

---

---

### STEP (B): Connect the Second-Tier MCCAT Switch to the Base Switch

Connect MCCAT switches that have been programmed as second-tier devices to the MCCAT base switch. You can mix different MCCAT models in the system. For example, you may connect the MCCAT28 switch to the MCCAT216 base switch.

► **To cascade KVM switches:**

1. Turn OFF all MCCAT switches and the base switch.
2. Connect the second-tier MCCAT switch to the base switch via a Cat5 UTP cable.
  - a. Plug one end of the Cat5 UTP cable into the **User 2** port on the second-tier MCCAT switch.
  - b. Plug the other end of the Cat5 UTP cable into one of the channel ports on the base switch.

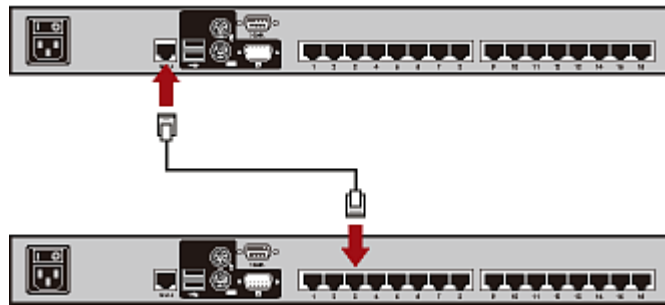

---

*Tip: You can also connect "one-user" MCCAT switches to the base switch. See **How to Connect MCCAT18/116 Switches to the Base Switch** (on page 83) in the User Guide.*

---

3. Repeat previous step(s) to connect other second-tier MCCAT switches to the base switch.
4. Turn ON all second-tier devices.
5. After hearing the beep sound from the second-tier devices, turn ON the base switch.

---

**Important: Make sure you turn on second-tier devices before turning on the base switch so that the base switch downloads up-to-date channel data from second-tier devices.**

---

---

**STEP (C): Connect Input/Output Devices to the Base Switch**

There are two ways to connect input/output devices (keyboard, mouse and monitor) to the base switch:

- Directly connect them to the base switch.
- Connect them to the user station, which is connected to the base switch.

► **To connect input/output devices directly to the base switch**

Connect a PS/2 or USB keyboard, mouse, and a VGA monitor to the base switch. See Step 6 of **Making the Connection** (on page 15) for more information.

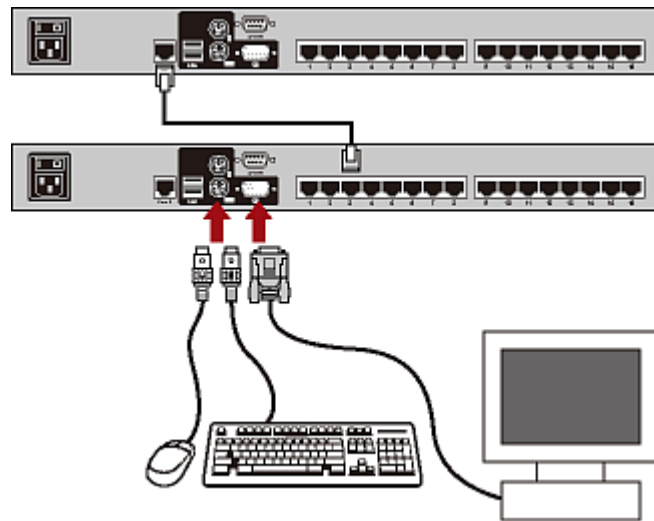

► **To connect input/output devices to the base switch via the user station**

1. Connect a PS/2 or USB keyboard, mouse, and a VGA monitor to the MCCAT user station.

2. Connect the MCCAT user station to the base switch. For more information, see the *Quick Setup Guide* shipped with the user station or **Connecting a User Station (Optional)** (on page 19) in the User Guide.

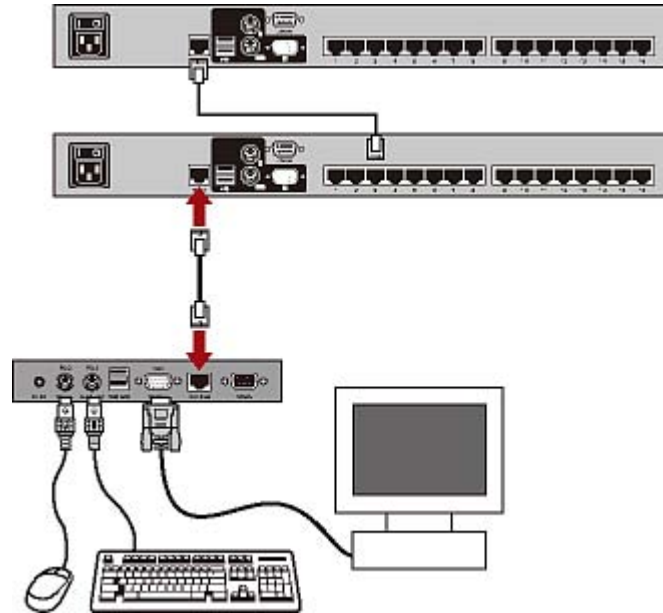

---

*Note: You can also connect input/output devices directly to the "second-tier devices." If you operate the input/output devices (keyboard, mouse and monitor) connected directly to a second-tier device, you only gain access to the channels of that specific second-tier device.*

---

**STEP (D): Specify the Type of the Second-Tier Device on the OSD**

The MCCAT base switch cannot detect which types of devices are connected to the channel ports. You must specify the types properly on the Channel Configuration submenu. Otherwise, there are problems accessing the channels on the second-tier devices.

The table lists supported devices.

OSD option	Device type
CPU	Computer or any non-KVM-switch device, such as a router
CAT18	MCCAT18 switch
CAT116	MCCAT116 switch
CAT28	MCCAT28 switch
CAT216	MCCAT216 switch

► **To specify the device type:**

1. If you do not see the OSD on the screen, press the hot key twice QUICKLY to activate it. The default hot key is Scroll Lock.
2. Press F5. The Administration Menu appears.
3. Select the third submenu, Channel Configuration. To select the submenu, either press 3, or press ↓ to highlight it and then press Enter. The Channel Configuration submenu appears.
4. Press ↓ or ↑ to highlight the channel whose device type you want to change.
5. Press Tab or → to select the field in the Device column, and press Enter. The highlight color turns green.
6. Press any arrow key to switch between available options, and press Enter to confirm your selection. The highlight color turns yellow.
7. Repeat Steps 4 to 6 until you specify correct device types for all second-tier devices.
8. Press S to save the changes or Esc to quit the current menu or submenu.
  - If pressing Esc, the message “Save the changes [Y/N/ESC]” appears on the message bar. Press Y to save the changes, N to abort the changes, or Esc to return to the current menu or submenu.



---

### STEP (E): Connect Computers to the MCCAT System

You can connect computers to available channel ports of any KVM switch in the system, including channel ports on the base switch and second-tier devices. See Steps 1 to 4 of **Connecting the Equipment** (see "Making the Connection" on page 15) for instructions on connecting computers.

MCIMs and MCUTP cables are mutually exclusive for making computer connections to a **second-tier** MCCAT28/216 switch. If both types are used to connect computers to a second-tier switch, video or OSD issues may occur.

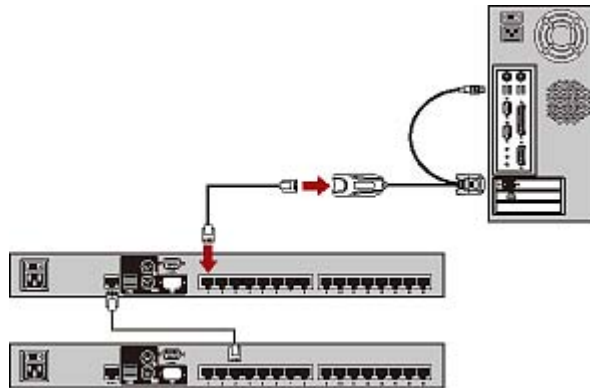

---

### Setting Up the Second-Tier Channels

If you want to name or rename the channels of the second-tier MCCAT switches, or change their scan rates, you must trigger the Channel Configuration submenu of second-tier devices.

► **To activate the Channel Configuration submenu of the second-tier devices:**

1. If you do not see the OSD on the screen, press the hot key twice QUICKLY to activate it. The default hot key is Scroll Lock.
2. Press F5. The Administration Menu appears.
3. Select the third submenu, Channel Configuration. To select the submenu, either press 3, or press ↓ to highlight it and then press Enter. The Channel Configuration submenu appears.
4. If you do not find the channel on the current page, press Page Down or Page Up to go to the next or previous page.
5. Press ↓ or ↑ to highlight the channel where a second-tier MCCAT switch is connected, and press G. The Channel Configuration submenu of the selected second-tier device appears.
6. Now you can change the channel settings of the second-tier device.

- To change the channel names, see **Assigning or Modifying Channel Names** (on page 45).
  - To change the scan rates, see **Changing the Scan Rate** (on page 46).
7. Press S to save the changes or Esc to quit the current menu or submenu.
    - If pressing S, then you can press Esc to return to the Channel Configuration submenu of the base switch.
    - If pressing Esc, the message “Save the changes [Y/N/ESC]” appears on the message bar. Press Y to save the changes, N to abort the changes, or Esc to return to the current menu or submenu.

---

*Note: The second-tier channel names that you specify after logging in to the base switch are saved in the database of the base switch, not on each second-tier device. Therefore, these channel names are unavailable when you access the second-tier device by using the keyboard and mouse directly connected to it.*

---

## Accessing the Second-Tier Channels

The two-tier system automatically disables all front panel buttons on the second-tier devices so the only method to access the second-tier channels is the OSD. If you have properly established the two-tier system, you should be able to see the second-tier channels on the base switch's OSD.

### ► To access the second-tier channels:

1. If you do not see the OSD on the screen, press the hot key twice QUICKLY to activate it. The default hot key is Scroll Lock.
2. Press **↓** or **↑** to highlight the channel where the second-tier device is connected. A channel connected to a second-tier device shows dashes (- -) in the Scn column.

---

*Tip: You can press the corresponding number shown in the No column for that channel to quickly highlight it.*

---

3. Press Enter. The Selection Menu lists the channels of the selected second-tier device.
4. If you do not find the channel on the current page, press Page Down or Page Up to go to the next or previous page.
5. Press **↓** or **↑** to highlight the channel you want.
6. Press Enter.

The video of the accessed computer appears on the screen. You can control the computer with the keyboard and mouse.

---

### Limitations of the Two-Tier System

The two-tier system has several limitations.

- There is only one path (Cat5 UTP cable) between the base switch and each second-tier device. When a user from the base switch is accessing any channel of a second-tier device, there are no other paths left for the other user from the base switch to access the same second-tier device's channels.
- The user from the base switch always shares second-tier channels with the "local" user, who operates the keyboard and mouse directly connected to the second-tier device. This is because the PC Share mode is automatically applied to all second-tier devices regardless of the operation mode selected at the base switch.
- If you operate the input/output devices (keyboard, mouse and monitor) connected directly to a second-tier device, you only gain access to the channels of that specific second-tier device.

---

### Returning to the Base Switch's OSD

After finishing your tasks with the second-tier computers, you can return to the Selection Menu of the MCCAT base switch for dealing with the computers connected to the base switch or accessing another second-tier device.

► **To return to the Selection Menu of the base switch:**

1. If you do not see the OSD on the screen, press the hot key twice QUICKLY to activate it. The default hot key is Scroll Lock.
2. Press F2 if the current OSD menu is not the Selection Menu.
3. Press Esc. Now the Selection Menu lists the channels of the base switch, with the base switch's name displayed on the top-left corner.

# Chapter 7 Keyboard Layout Settings (for Sun USB MCUTP Cable)

Different language versions of keyboards are provided for use in different countries. For example, the layout of a French keyboard is different from that of a US English keyboard. With the Sun USB MCUTP cable, you can change the keyboard's layout setting to match your keyboard type if you are not using a US English keyboard (the factory default).

---

*Note: The keyboard-layout change function is not applicable to USB or PS/2 MCIM and MCUTP cable.*

---

## In This Chapter

Changing Keyboard Layout Settings.....	68
Keyboard Layout Codes.....	70

---

## Changing Keyboard Layout Settings

When you connect a Sun USB MCUTP cable to a Sun server and your keyboard is not US English (code 33), you have to change the keyboard layout setting by entering the keyboard setting mode.

► **To change the keyboard layout setting:**

1. Highlight the channel of the desired server on the Selection Menu, and press Enter.
2. Activate a text editor on the server.

3. Press Left Ctrl + NumLock to enter the setting mode. A message similar to the following appears in the text editor.

```

Cable C1m Susb 0A2
Bootloader version is 01
----
keyboard layouts
33 english us
32 english uk
08 french
09 german
26 swedish
19 norwegian
15 japanese
25 spanish
14 italian
16 korean
----
current options
keyboard layout is 33
    
```

<b>A</b>	Frequently-used keyboard layout codes
<b>B</b>	Current keyboard layout is US English (code 33)

4. Press the appropriate keyboard layout code, and then the last line shows the newly-typed code. For example, if you type the Japanese keyboard code 15, the last line shows the keyboard layout is 15.

```

Cable C1m Susb 0A2
Bootloader version is 01
----
keyboard layouts
33 english us
32 english uk
08 french
09 german
26 swedish
19 norwegian
15 japanese
25 spanish
14 italian
16 korean
----
current options
keyboard layout is 3315
keyboard layout is 15
    
```

<b>C</b>	Newly-changed keyboard code
----------	-----------------------------

5. Press Esc to exit the setting mode.
6. Log out of the server.
  - If a message appears, asking whether you want to save the text file, you can ignore it.
7. Log in to the server.

---

**Important: You must log out of the server and then log back in for the changed keyboard setting to be effective.**

---

## Keyboard Layout Codes

The keyboard setting mode displays only frequently-used keyboard layout codes on the screen. For other layout codes, see the table.

Language	Layout code	Language	Layout code
Arabic	01	Netherlands	18
Belgian	02	Norwegian	19
Canadian-Bilingual	03	Persian	20
Canadian-French	04	Poland	21
Czech Republic	05	Portuguese	22
Danish	06	Russia	23
Finnish	07	Slovakia	24
French	08	Spanish	25
German	09	Swedish	26
Greek	10	Swiss/French	27
Hebrew	11	Swiss/German	28
Hungary	12	Switzerland	29
International (ISO)	13	Taiwan	30
Italian	14	Turkish	31
Japan	15	UK	32
Korean	16	USA (Default)	33
Latin American	17	Yugoslavia	34

## Chapter 8 User Station Direct Mode

Sometimes when you have to cope with an emergency, such as the crash cart operation, you may need to connect the MCCAT user station to the computer directly. This is called Direct Mode.

► **To connect the MCCAT user station to the computer:**

1. Ensure that the MCIM or MCUTP cable remains connected to the computer that you want to operate. For information on connecting the MCIM or MCUTP cable, see **Connecting the Equipment** (see "Making the Connection" on page 15).
2. Ensure that the keyboard, mouse and monitor remain connected to the **MCCAT user station** (see "Connecting a User Station (Optional)" on page 19).
3. Connect the computer to the MCCAT user station with a cable up to 100 feet (30.48 meters). A cable longer than 100 feet may degrade the video quality.
  - If using the MCIM:
    - a. Plug one end of the Cat5 UTP cable into the RJ-45 port of the MCIM being connected to the computer.
    - b. Plug the other end of the cable into the Cat5 Port of the user station.

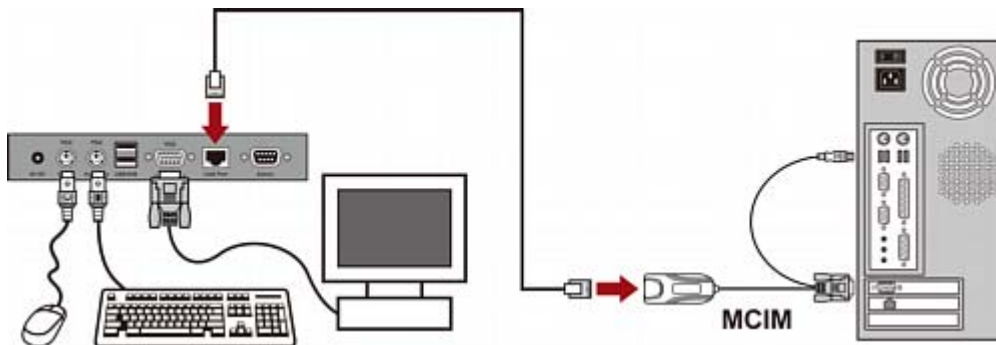

- If using the MCUTP cable:
  - Plug the RJ-45 connector of the cable into the Cat5 Port of the user station.

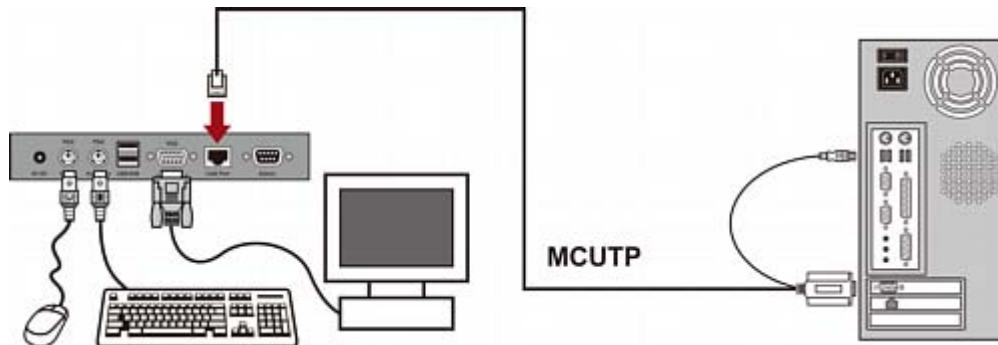

---

*Note: If any abnormal video issues occur, power cycle the MCCAT user station by unplugging and re-plugging its power adapter to resolve the problem.*

---



# Chapter 9    Firmware Upgrade

You can upgrade the firmware to benefit from the latest enhancements and features whenever new firmware is released on the Raritan website. The upgrade procedure for the MCCAT switch and MCCAT user station is the same, but the required firmware file is different. The upgrade process involves three steps:

- STEP (A): Download the latest firmware and upgrade utility
- STEP (B): Connect the desired device to the computer running the upgrade utility
- STEP (C): Launch the upgrade utility
- 

If your system consists of multiple MCCAT switches, you should upgrade each of them.

### In This Chapter

STEP (A): Download the Latest Firmware and Upgrade Utility.....	73
STEP (B): Connect the Desired Device to the Computer Running the Upgrade Utility .....	74
STEP (C): Launch the Upgrade Utility.....	75

---

## STEP (A): Download the Latest Firmware and Upgrade Utility

1. Use your browser to visit **Raritan website** (<http://www.raritan.com>).
2. Click **Support > Firmware and Documentation**.
3. Locate the product name on the left pane and click it.
4. Click the appropriate version (or model) on the right pane.
5. Click **Firmware Upgrade**. The webpage showing a list of firmware files opens.
  - If this is your first time to download the firmware from the Raritan website, the Firmware Request form opens. Fill in the form, and click **Submit**.
6. When you see the hyperlinks or files on the right pane, click the appropriate one.
7. Click **Save** to save the file on your computer.
8. Specify the location where you want to save the file, and click **Save**. Wait until the download completes.
9. Extract the file if it is a compressed file.

10. (Optional) If the downloaded file does not include the 'release notes' document, locate the release notes on the Firmware and Documentation section, and double-click it to open or download it.
11. Read the release notes for any necessary information.

---

## STEP (B): Connect the Desired Device to the Computer Running the Upgrade Utility

Prepare one DB9 male-to-female serial (RS-232) cable, and use it to connect the MCCAT switch or MCCAT user station to the computer where the upgrade utility is installed.

---

*Note: If you don't have the cable, contact Raritan Technical Support for assistance.*

---

1. Plug one end of the serial cable into one of the computer's serial ports.
2. Plug the other end into the **Admin** port of the MCCAT switch or MCCAT user station.

- **MCCAT User Station Connection**

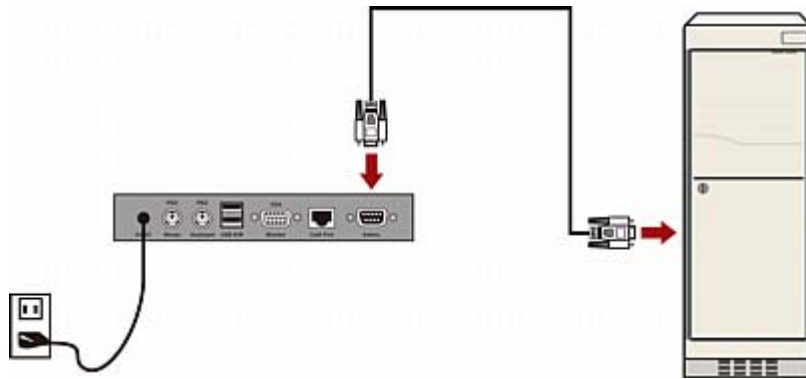

- **MCCAT Switch Connection**

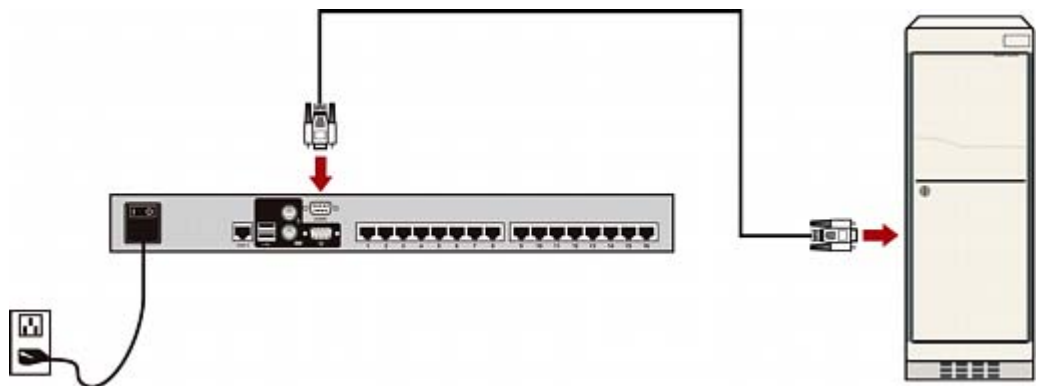

## STEP (C): Launch the Upgrade Utility

The upgrade utility for MCCAT switch and MCCAT user station is the same one for Raritan Paragon devices, that is, the Paragon Update utility. Paragon Update utility older than 2.4.3 does not support upgrading the MCCAT switch and MCCAT user station. To ensure the success of the upgrade, always use the latest upgrade utility downloaded along with the MCCAT firmware.

1. Double-click the upgrade utility—`ParagonUpdate_xxx.exe`, where `xxx` represents the version number. The Paragon Update utility opens.

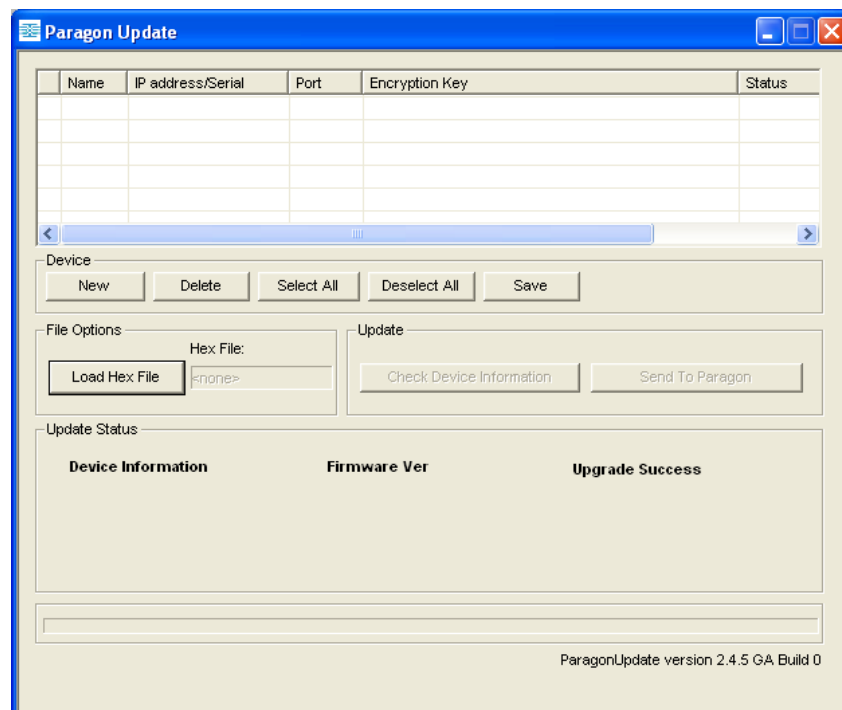

2. If the device that you want to upgrade is already listed in the dialog, go to Step 3. If not, follow this procedure to specify the device information:
  - a. Click New to add the device information.
  - b. Click the Name field and type the appropriate name for the device that you want to upgrade.
  - c. Ensure <Default Serial> is selected in the IP address/Serial field.
  - d. Click the Port field and type the appropriate number of the serial port. For example, if the device connects to the computer via COM 1, type 1, if via COM 2, type 2.
  - e. Ensure <Default No Encryption> is selected in the Encryption Key field.

- f. (Optional) Click Save to save the device information so that next time you don't have to specify the same information again.

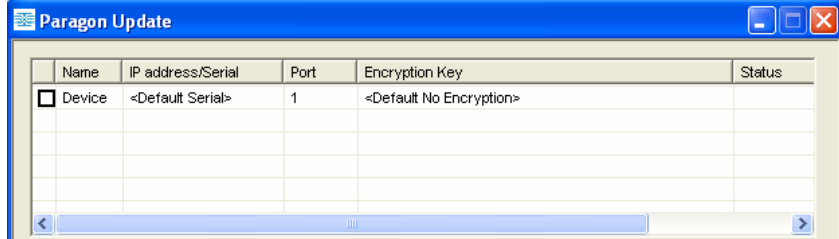

- 3. Select the checkbox next to the device that you want to upgrade.

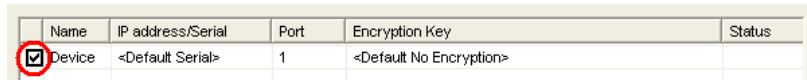

- 4. Click Load Hex File. The Open dialog appears.
- 5. Navigate to where the appropriate firmware file (\*.hex) is stored, select it and click Open. Firmware files for different devices are different:

Device	Filename syntax (*.hex)	
KVM switch	MCCAT28 or MCCAT216	mcc2-xxx**
	TMCAT1728 or TMCAT17216	tm-mcc2-xxx**
MCCAT user station	MCCUST-xxx**	

\*\*xxx represents the firmware version number.

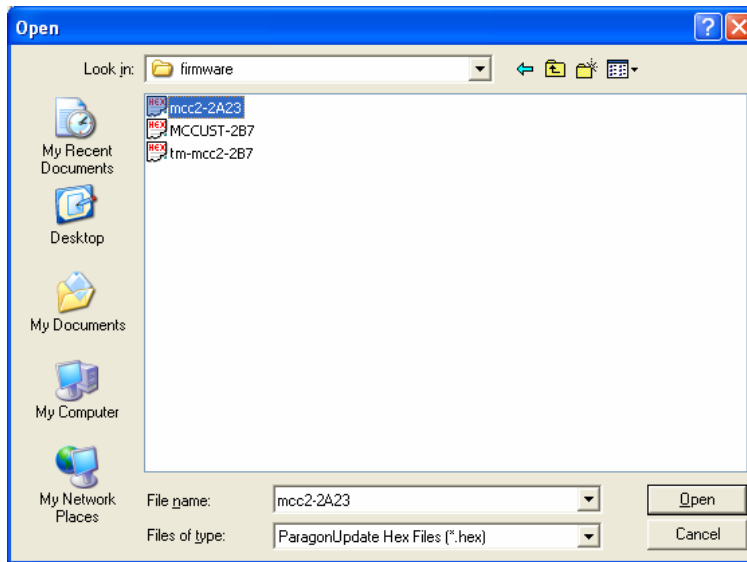

6. (Optional) If you want to view the current hardware and firmware version of the device, click Check Device Information.
  - a. Click Yes. The Check Device Information window opens.
  - b. To quit the window, click OK.

---

*Note: MCCAT and TMCAT17 series belong to the same hardware type. The Check Device Information window always shows the hardware is MCCAT no matter the connected KVM switch is MCCAT or TMCAT17 series.*

---

7. Click Raritan MasterConsole to perform the upgrade.
8. Click Yes when this message appears.

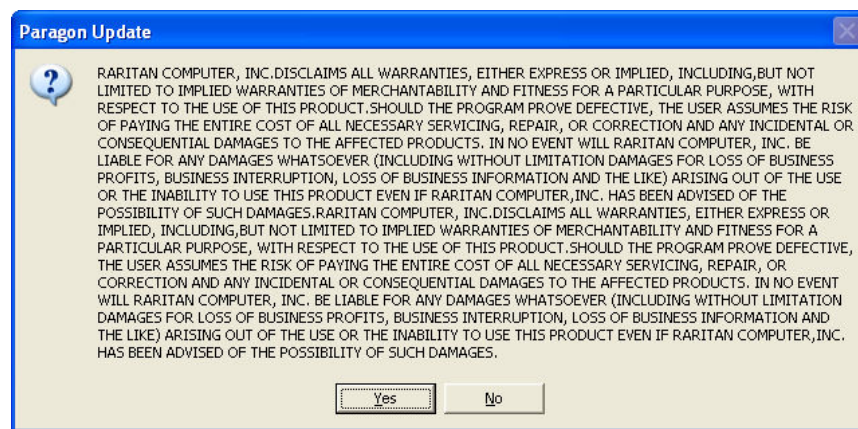

9. A progress indicator at the bottom of the dialog displays the upgrade status. The upgrade may last for several minutes.

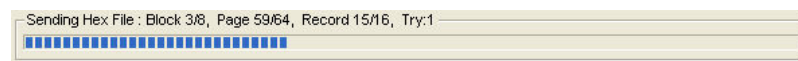

10. The "Device Update Successful" message appears when the upgrade is finished successfully. Click OK.



For more information on the Paragon Update utility, download the *Paragon Manager User Guide* from Raritan's ***Firmware and Documentation webpage*** (<http://www.raritan.com/support/firmware-and-documentation/>).

# Appendix A Specifications

## In This Chapter

Measurement.....	78
Power.....	78
Operating Environment.....	78
Supported Resolutions .....	79

---

### Measurement

MCCAT28 (8-channel model)	1U rackmountable	<b>Dimension:</b> 17.32"(W) x 7.76"(D) x 1.73"(H) or 44 cm (W) x 19.7 cm (D) x 4.4 cm (H)	<b>Weight:</b> 5.40 lb or 2.45 kg
MCCAT216 (16-channel model)	1U rackmountable	<b>Dimension:</b> 17.32"(W) x 7.76"(D) x 1.73"(H) or 44 cm (W) x 19.7 cm (D) x 4.4 cm (H)	<b>Weight:</b> 5.42 lb or 2.46 kg
MCCAT-UST		<b>Dimension:</b> 7.19"(W) x 3.94"(D) x 1.17"(H) or 18.3 cm (W) x 10 cm (D) x 3 cm (H)	<b>Weight:</b> 1.19 lb or 0.54 kg

---

### Power

MCCAT28	100V~240V auto sensing, 20 Watts
MCCAT216	100V~240V auto sensing, 20 Watts
MCCAT-UST	DC 6V

---

### Operating Environment

Operation	0°~40° C
Storage	-5°~60° C
Relative humidity	5~90%, non-condensing

---

**Supported Resolutions**

Screen resolution	Refresh rate (HZ)
640x350	70, 85
640x400	85
640x480	60, 67, 72
720x400	70, 85
800x600	56, 60, 70, 72, 75, 85, 100
1024x768	60, 70, 75, 85, 100
1152x864	75
1152x870	75
1280x960	60, 85
1280x1024	60, 75, 85
1600x1200	60

# Appendix B Cable Length Limitations

You should limit the Cat5 cable length between MCCAT system components and connected computers for keeping optimal video quality. This section lists the maximum cable length or distance supported in different scenarios.

## In This Chapter

Maximum Distance between Users and MCCAT Switches .....80  
 Maximum Distance between Users and Computers .....80  
 Maximum Distance for User Station Direct Mode .....81

---

### Maximum Distance between Users and MCCAT Switches

The cable length or distance between the MCCAT user station and MCCAT switch cannot exceed 100 feet.

#### Supported length

X= up to 100 feet (30.48 meters)

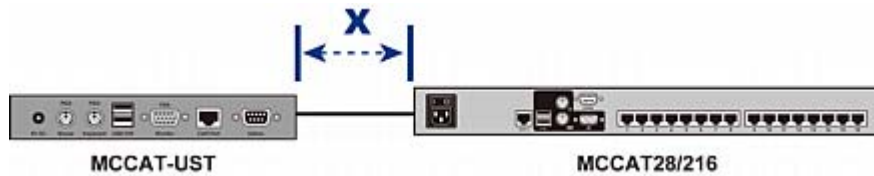



---

### Maximum Distance between Users and Computers

Maximum cable length or distance between users and computers varies depending on video resolutions.

Resolution	Supported length
1280x1024 or below	X*+Y= up to 150 feet (45.72 meters)
1600x1200	X*+Y= up to 100 feet (30.48 meters)

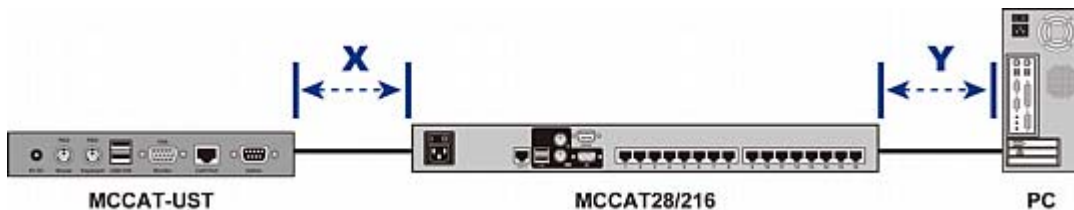
\* X can be up to 100 feet. See **Maximum Distance between Users and MCCAT Switches** (on page 80).







# Appendix C Compatibility with Other Raritan Products

MCCAT28 and MCCAT216 switches can work in conjunction with other Raritan devices, including:

- Analog KVM switches, such as MCCAT18 and MCCAT116
- Most of Paragon, Dominion and Serial CIMs.
- Paragon II enhanced user station -- P2-EUST

## In This Chapter

Compatible KVM Switches.....	82
Compatible CIMs.....	85
P2-EUST User Station .....	89

---

## Compatible KVM Switches

"Two-user" MCCAT switches can work with these Raritan KVM switches to form a two-tier system:

- "One-user" MCCAT switches, including MCCAT18 and MCCAT116
- TMCAT17 KVM drawers, including TMCAT17218 and TMCAT17216

---

### One-User MCCAT Switches

You can connect "one-user" MCCAT switches to a MCCAT28 or MCCAT216 base switch for organizing a two-tier system.

Follow the major steps described in **Establishing a Two-Tier System** (on page 60) to install "one-user" MCCAT switches as second-tier devices. The only difference is that a "one-user" MCCAT switch does not have the **User 2** port so the way to connect it is different from the way to connect a "two-user" MCCAT switch. For instructions on connecting "one-user" MCCAT switches, see **How to Connect MCCAT18/116 Switches to the Base Switch** (on page 83).

MCUTP cables are compatible with two-user MCCAT switches, but *incompatible* with "one-user" MCCAT switches so you must use MCIMs to connect computers to "one-user" MCCAT switches.

### How to Connect MCCAT18/116 Switches to the Base Switch

A "one-user" MCCAT switch requires one MCIM-PS2 for connecting to the base switch.

Do NOT use MCUTP cables or any CIM other than MCIM-PS2 to connect "one-user" MCCAT switches to the base switch.

► **To connect "one-user" MCCAT switches to the two-user MCCAT base switch**

1. Turn OFF all MCCAT switches.
2. Connect one MCIM-PS2 to the MCCAT18 or MCCAT116 switch that has been programmed as a second-tier device:
  - a. Plug the MCIM's PS/2 keyboard connector into the PS/2 keyboard port on the second-tier MCCAT switch.
  - b. Plug the MCIM's PS/2 mouse connector into the PS/2 mouse port on the second-tier MCCAT switch.
  - c. Plug the MCIM's video connector into the VGA port on the second-tier MCCAT switch.

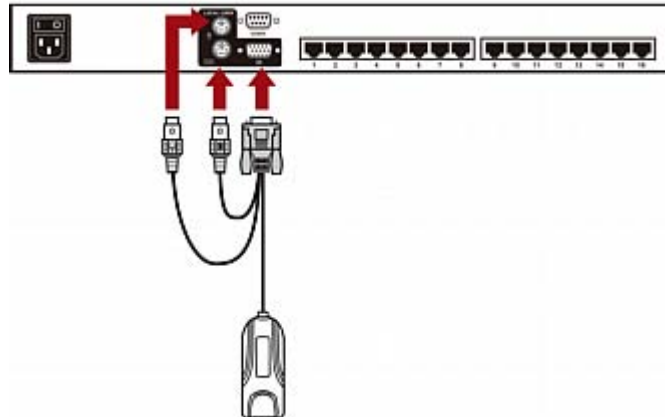

3. Connect the second-tier MCCAT switch to the first-tier switch (base switch) via a Cat5 UTP cable.
  - a. Plug one end of the Cat5 UTP cable into the RJ-45 port of the MCIM being connected with the second-tier MCCAT switch.

- b. Plug the other end of the Cat5 UTP cable into one of the channel ports on the base switch.

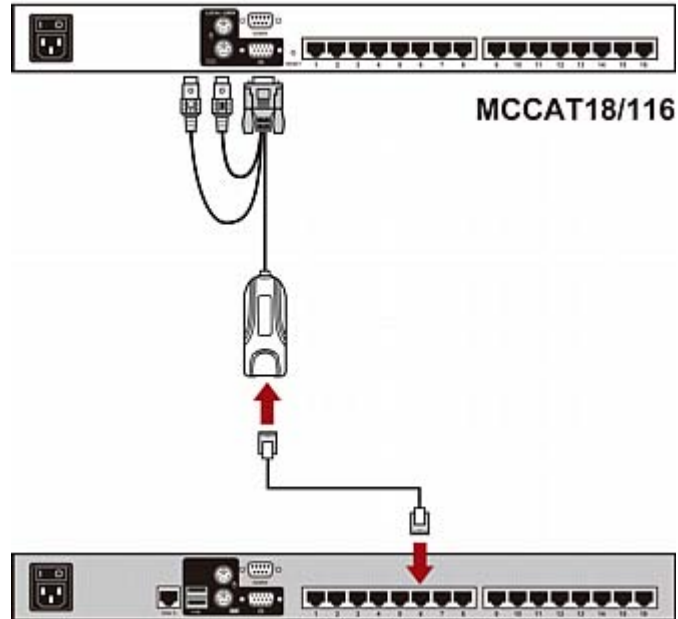

4. Repeat previous step(s) to connect other second-tier MCCAT switches to the base switch.
5. Turn ON all second-tier devices.
6. After hearing the beep sound from the second-tier devices, turn ON the base switch.

---

**Important: Make sure you turn on second-tier devices before turning on the base switch so that the base switch downloads up-to-date channel data from second-tier devices.**

---

### TMCAT17 Switches

You can connect "two-user" MCCAT switches to a TMCAT17 base switch. Its tiering procedure is mostly the same as the tiering procedure for a "two-user" MCCAT base switch. For details, see the TMCAT17 User Guide, which can be downloaded from the **Raritan website** (<http://www.raritan.com>).

The diagram depicts a two-tier TMCAT17 system.

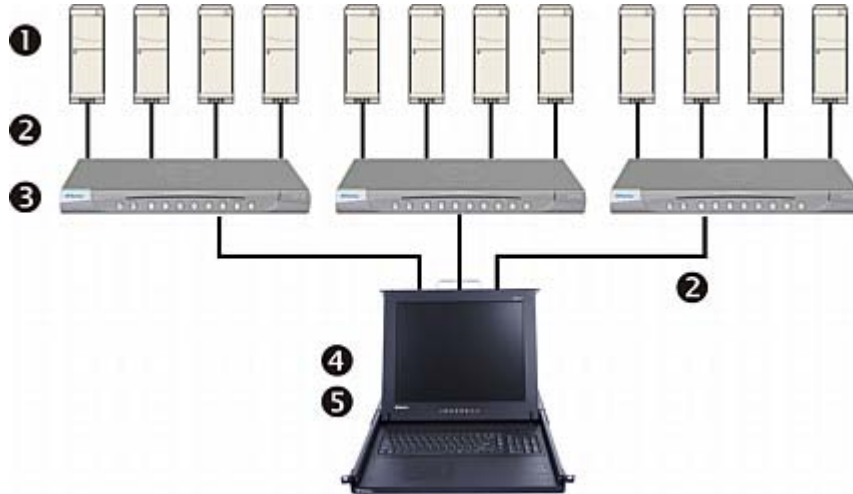

①	Computers
②	Cat5 UTP cables
③	Second-tier MCCAT switches
④	TMCAT17 base switch (the first tier)
⑤	Input/output devices (keyboard, mouse, and monitor)

TMCAT17 switches *cannot* function as the second-tier devices so you cannot connect them to a "two-user" MCCAT base switch.

### Compatible CIMs

In addition to MCIM-PS2 and MCIM-USB, the MCCAT switch is also compatible with other Raritan Computer Interface Modules (CIMs). See the table in this section for information.

The way to connect these CIMs is the same as the way to connect MCIMs. See **Connecting the Equipment** (see "Making the Connection" on page 15) for how to connect an MCIM.

<b>CIM</b>	<b>Connector type</b>
P2CIM-APS2	PS/2 and HD15 (video) connectors
P2CIM-AUSB	USB and HD15 (video) connectors
DCIM-PS2	PS/2 and HD15 (video) connectors
DCIM-USB	USB and HD15 (video) connectors
DCIM-USB G2 *	USB and HD15 (video) connectors
P2CIM-SER	RS-232 (serial) and USB connectors
P2CIM-SER-EU	RS-232 (serial) and USB connectors

*\* When connecting a DCIM-USB G2 to the computer, ensure the slide switch on the back of the CIM is moved to P for PC-based servers or moved to S for SUN servers.*

---

*Note: Although the MCCAT switch supports the use of P2CIM-APS2, it does NOT support the Pinnacle FastAction keyboard that P2CIM-APS2 supports.*

---

---

### Connecting a Serial Device via the Serial CIM

To connect an ASCII serial device, LAN/WAN component or a computer through an RS-232 serial port to the MCCAT system, use one of Raritan's serial CIMs: *P2CIM-SER* or *P2CIM-SER-EU*. These CIMs can emulate an ASCII terminal and convert the serial data from the ASCII device to VGA video (800x600x60) and PS/2 keyboard signals. With this conversion, you can access and operate any ASCII serial device connected to the system.

#### Here are some useful features of the serial CIMs:

- Interoperates with an ASCII device in the On Line Mode as if the device were connected to a text terminal
- Edits, copies, marks, and resends data to the ASCII serial device or computer in the Buffer Edit Mode
- Maintains eight pages of data in a circular buffer
- Provides 12 programmable keys for frequently-used character strings or commands

---

*Note: The P2CIM-SER and P2CIM-SER-EU are functionally identical. The only difference between the two is that the P2CIM-SER-EU supports a wider variety of non-English language keyboards and character sets.*

---



❶	DB9 connector
❷	USB connector
❸	RJ-45 connector

The installation of P2CIM-SER or P2CIM-SER-EU is quite easy.

#### ► To install a Serial CIM:

1. Connect the CIM to a serial port on the serial device or computer, using its serial DB9 connector.
2. Connect the CIM to the KVM switch, using a standard Cat5 UTP cable.

3. Plug the CIM's USB connector into a powered USB port, or into a separately available Raritan PWR-SER-4 power adapter, to obtain power.

For detailed information on the CIMs, see *Paragon and Dominion KX Serial Device CIM User Guide*, which is downloadable from the **Raritan website** (<http://www.raritan.com>).

► **To download the Paragon and Dominion KX Serial Device CIM User Guide:**

1. Use your browser to visit Raritan's **Firmware and Documentation section** (<http://www.raritan.com/support/firmware-and-documentation/>).
2. On the left pane, click Paragon II > Other Support Files.
3. On the right pane, click P2CIM-SER User Guide.
4. Click *Paragon II CIM Serial User Guide* to open it.
5. (Optional) You can save it on your computer by clicking the Save icon.



## P2-EUST User Station

The MCCAT28 and MCCAT216 switches are compatible with the Paragon II enhanced user station (P2-EUST) *with the firmware version 3F0 or earlier*. If you have this device, you can use it in place of the MCCAT user station. Moreover, P2-EUST enables the user to be located at a distance up to 750 feet from the MCCAT switch. See **Supported Maximum Cable Length** (on page 90) for more information.

*Note: If your P2-EUST's firmware is higher than 3F0, you must downgrade the device to 3F0 or earlier versions for compatibility with MCCAT28/216 switches. For more information on P2-EUST, see the Paragon II User Guide, which can be downloaded from the Raritan website's **Firmware and Documentation** section (<http://www.raritan.com/support/firmware-and-documentation/>).*

► **To connect the P2-EUST user station to the MCCAT switch:**

1. Connect the PS/2 or USB keyboard and mouse to the user station.

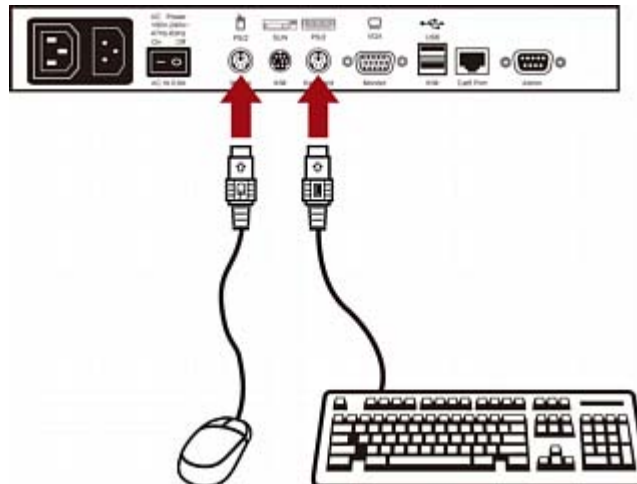

2. Connect the VGA monitor to the user station.

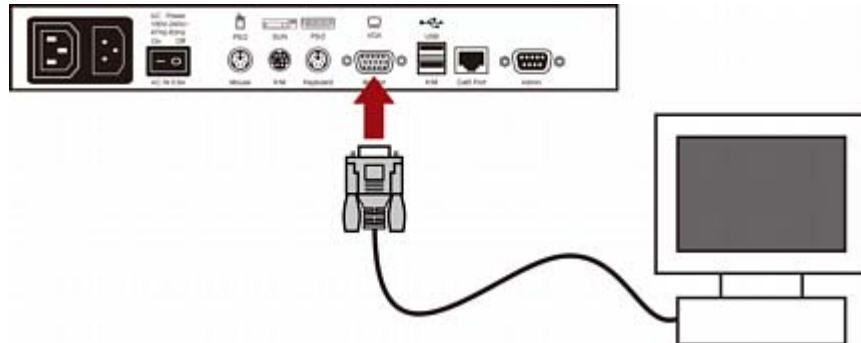

3. Connect the user station to the KVM switch via a standard Cat5 UTP cable.

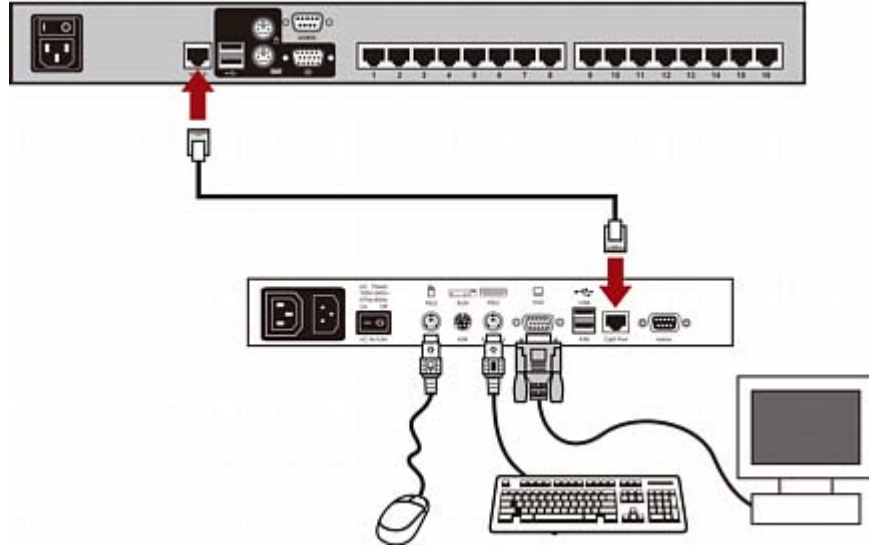

4. Connect the power cord to the user station.
5. Turn on the user station and the monitor.

*Note: Although the MCCAT switch supports the P2-EUST device, it does not support the Automatic Skew Compensation feature that is implemented with the P2-EUST device.*

### Supported Maximum Cable Length

The total cable length or distance between the P2-EUST user station and the computer can be up to 750 feet (228.6 meters).

#### Supported cable length

X= up to 750 feet (228.6 meters)

Y= up to 100 feet (30.48 meters) at 1600x1200, or up to 150 feet (45.72 meters) at 1280x1024 or below

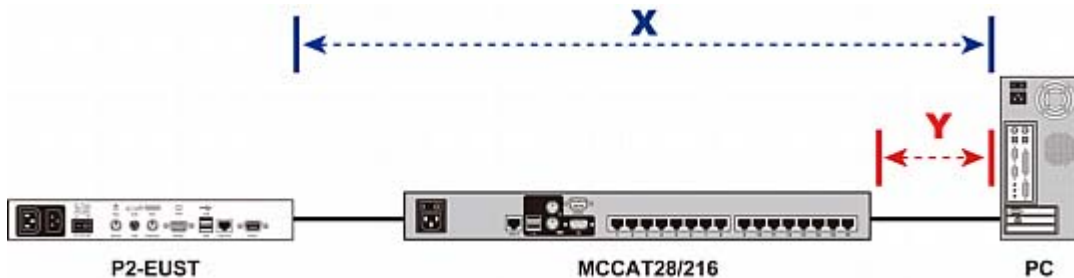

## Appendix D Default Settings

Field or function	Factory default
Administrator password	raritan (all lower case)
User passwords	No passwords for any user account (User01~User07)
Scan rate	5 seconds per channel
Operation Mode	Private
ID Display	On
▪ Timing	3 seconds
Green Mode	Off
▪ Timing	5 minutes
Hotkey	Scroll Lock
Login Blank	Off
▪ Timing	5 minutes
Logoff Timeout	On
▪ Timing	5 minutes

## Appendix E Troubleshooting

Problem	Solution
No power	<ul style="list-style-type: none"> <li>• Check the power cord.</li> <li>• Make sure the power switch is turned ON.</li> <li>• Check the cable connection from the computer to the MCCAT switch.</li> </ul>
No video display for one or all computers	<ul style="list-style-type: none"> <li>• Check the CIM's video connection to the computer.</li> <li>• Check the monitor and computer connected to the MCCAT switch: Turn off the MCCAT switch and computers. Connect the monitor to the computer directly, boot the computer, and make sure the monitor has the proper display. If it does not, the problem is either with your computer, or the monitor is not compatible with your computer. If it does display, continue the troubleshooting below.</li> </ul>
The monitor cannot correctly display the video output from some of the computers	<ul style="list-style-type: none"> <li>• The monitor probably does not match the video outputs. If the monitor is a single mode type VGA, all computers must have the same type of video output.</li> <li>• <i>(Note: this problem occurs most often with some IBM PS/2s and IBM 63xx, 85xx, and 95xx monitors.)</i> The intelligent type display card outputs video signals based on the monitor ID-pin setting in the connector of the monitor cable. If the ID-pin setting is incorrect, the monitor connected to the MCCAT switch may have no display, become monochrome instead of color, or become unstable. If this is the case, you will need to provide a proper ID-pattern to the display card. Call Raritan Technical Support (see the last page) for help if necessary.</li> </ul>
All computers powered up without keyboard error, but the keyboard connected to the MCCAT switch has no control (cannot input to any computer)	<ul style="list-style-type: none"> <li>• Make sure the keyboard is connected firmly to the MCCAT switch. Disconnect and reconnect the keyboard.</li> <li>• Replace the keyboard. (The MCCAT switch allows hot re-connection of the keyboard.)</li> <li>• In a two-tier configuration, check that the MCCAT switch with the keyboard connected is the first tier.</li> </ul>
Repeated "KB ERROR" at power-up of computer	<ul style="list-style-type: none"> <li>• The CIM's keyboard cable to the computer is loose. Secure the connection and turn on the computer again.</li> <li>• If the problem occurs after the MCCAT switch has been installed for a period of time, and occurs on computers that have previously worked with the MCCAT switch, then some components are out of order. Verify that the computer works with the keyboard when connected directly. Then contact your dealer or Raritan for help.</li> </ul>
After a period of trouble-free operation, the keyboard connected to the MCCAT switch	<ul style="list-style-type: none"> <li>• The most likely cause of the problem is either a voltage "spike" (increase) or a "brown out" (decrease) in the power supply, which would cause the microprocessors in the MCCAT switch to malfunction. A short-term solution to the problem is to try to recover</li> </ul>

Problem	Solution
locks (unable to input keystrokes) when a particular computer is selected, but works normally when other computers are selected	<p>operation by turning the MCCAT switch off and on. Then, if necessary, restart all computers. The long-term method of avoiding this problem is to power the MCCAT switch from a UPS.</p> <ul style="list-style-type: none"> <li>• Check the keyboard connection.</li> </ul>
Repeated "MOUSE INSTALLATION FAILURE" at power-up of computer	<ul style="list-style-type: none"> <li>• The CIM's mouse cable to the computer is loose. Secure the connection and turn on the computer again.</li> <li>• If the problem only occurs to new computers which are just added to the system, the firmware in the KVM (MCCAT internal mouse emulator) may need to be upgraded to a later version to be compatible with newer computers. Contact your dealer or Raritan for help.</li> </ul>
After a period of trouble-free operation, the mouse connected to the MCCAT switch locks (unable to control mouse functions) when a particular computer is selected, but works normally when other computers are selected	<ul style="list-style-type: none"> <li>• Try to identify if the problem is originating from the computer by reconnecting the computer to a different channel with a different cable. Then turn on the computer. If the problem is not with the cable or with a specific channel, connect the mouse directly to the computer. If the problem persists, then the computer's mouse port is out of order. Otherwise, contact your dealer or Raritan for help.</li> <li>• If the problem occurs after the MCCAT switch has been installed for a period of time, and occurs to computers that have previously worked with the MCCAT switch, then some components are out of order. Contact your dealer or Raritan Technical Support for help.</li> </ul>
PS/2 keyboard or mouse does not work	You may have connected USB keyboard or mouse to the MCCAT device. Keep only one set of keyboard and mouse connected to the MCCAT device, and disconnect the other set.
Device does not operate in the OSD interface	Replace the keyboard. OSD interface works with regular PS/2, USB, or extended AT style keyboards.
The monitor cannot properly display the video output in the Direct mode	Power cycle the MCCAT user station by unplugging and re-plugging its power cord.



# Index

## A

Accessing a Computer or Channel • 23, 43  
Accessing Active Channels Only • 37, 38  
Accessing the Second-Tier Channels • 66  
Activating the Help Menu • 41  
Activating the OSD • 29  
Active Channels • viii, 8, 30  
Adding User Accounts • 53  
Adjusting the ID Display Position • 56  
Adjusting the OSD Menu Position • 57  
Advanced Operation • 11, 34  
Assigning or Modifying Channel Names • 45, 47, 66  
Attaching the Cable-Support Bar (Optional) • 12

## B

Basic Installation • 15

## C

Cable Length Limitations • viii, 80  
Changing Keyboard Layout Settings • viii, 68  
Changing Passwords • 23, 47, 54  
Changing the Hot Key • 29, 48  
Changing the Operation Mode • 40, 49  
Changing the Scan Rate • 36, 46, 66  
Channel Colors • 29  
Channel Colors and Statuses • 31  
Combination Keys Table • 43  
Compatibility with Other Raritan Products • 82  
Compatible CIMs • 85  
Compatible KVM Switches • viii, 82  
Connecting a Serial Device via the Serial CIM • 87  
Connecting a User Station (Optional) • 18, 19, 63, 71  
Cycling Through Channels • 36, 43

## D

Default Settings • 91  
Deleting User Accounts • 54

## E

Emulating Special Sun Keys • 42  
Establishing a Two-Tier System • 60, 82

## F

Firmware Upgrade • 73  
Forward Mount • 13  
Front View • 7, 9

## H

Hiding the Login Box • 52  
How to Connect MCCAT18/116 Switches to the Base Switch • 61, 82, 83

## I

Inactive Channels • viii, 8, 30  
Introduction • 1  
Introduction to the OSD Interface • 26

## K

Keyboard Layout Codes • viii, 70  
Keyboard Layout Settings (for Sun USB MCUTP Cable) • viii, 68

## L

Limitations of the Two-Tier System • viii, 49, 67  
Login • 22, 34  
Login Box • 26  
Logout • 25

## M

Making the Connection • viii, 15, 41, 62, 65, 71, 85  
Managing User Accounts • 53  
Maximum Distance between Users and Computers • viii, 80  
Maximum Distance between Users and MCCAT Switches • viii, 80  
Maximum Distance for User Station Direct Mode • viii, 81  
MCCAT Computer Interface Module (MCIM) • 2  
MCCAT Switch • viii, 1, 5, 7  
MCCAT User Station • 2, 6, 9  
MCCAT User Station (Optional) • 7  
MCUTP Cable • viii, 2  
Measurement • 78

## O

One-User MCCAT Switches • viii, 82  
Operating Environment • 78

OSD Layout • 26  
OSD Menu • 27  
OSD Operation Keys • 31  
Overview • 59

## P

P2-EUST User Station • 18, 21, 89  
Package Contents • 6  
Power • 78  
Preparing Requisite Items • viii, 15  
Product Features • 5  
Product Overview • 1  
Product Photos • viii, 4

## Q

Quick Start • 11

## R

Rack-Mounting MCCAT Switches • 11  
Rear Mount • 13, 14  
Rear View • 8, 9  
Refreshing Channel Statuses • 8, 29, 43  
Renaming the MCCAT Switch • 26, 46  
Renaming User Accounts • 53, 54  
Resetting System Settings • 57  
Returning to the Base Switch's OSD • 67

## S

Selection Menu • 24, 28  
Setting Up the Channel ID Display Function • 55  
Setting Up the Green Mode • 50  
Setting Up the ID Display Function • 55  
Setting Up the Logoff Timeout Function • 51  
Setting Up the Second-Tier Channels • 45, 65  
Sharing the Computer • 40, 49  
Specifications • 78  
STEP (A)  
    Download the Latest Firmware and Upgrade Utility • 73  
    Programme an MCCAT Switch as a Second-Tier Device • 7, 34, 44, 58, 60  
STEP (B)  
    Connect the Desired Device to the Computer Running the Upgrade Utility • 74  
    Connect the Second-Tier MCCAT Switch to the Base Switch • 61  
STEP (C)

    Connect Input/Output Devices to the Base Switch • 62  
    Launch the Upgrade Utility • 75  
STEP (D)  
    Specify the Type of the Second-Tier Device on the OSD • 64  
STEP (E)  
    Connect Computers to the MCCAT System • 65  
Structure Diagrams • 7  
Supported Maximum Cable Length • 89, 90  
Supported Resolutions • 79  
Supporting Sun Servers • viii, 17, 41  
Switching the Channel Sorting • 28, 35  
System Settings • 11, 31, 44

## T

TMCAT17 Switches • viii, 85  
Troubleshooting • 92  
Two-Tier System • 11, 59

## U

User Station Direct Mode • viii, 9, 71, 81  
Using Channel Buttons • 25  
Using the F6 Function Key • 37  
Using the F7 Function Key • 39  
Using the SCAN Button • 36  
Using the Selection Menu • 24  
Using the SKIP Button • 38

## V

Variations of Highlight Colors • 29

## W

What are Active and Inactive Channels • viii, 6, 8, 29, 30, 38  
What's New in the MCCAT User Guide • viii  
When to Emulate Sun Keys • 42





▶ **U.S./Canada/Latin America**

Monday - Friday  
8 a.m. - 6 p.m. ET  
Phone: 800-724-8090 or 732-764-8886  
For CommandCenter NOC: Press 6, then Press 1  
For CommandCenter Secure Gateway: Press 6, then Press 2  
Fax: 732-764-8887  
Email for CommandCenter NOC: tech-ccnoc@raritan.com  
Email for all other products: tech@raritan.com

▶ **China**

**Beijing**

Monday - Friday  
9 a.m. - 6 p.m. local time  
Phone: +86-10-88091890

**Shanghai**

Monday - Friday  
9 a.m. - 6 p.m. local time  
Phone: +86-21-5425-2499

**GuangZhou**

Monday - Friday  
9 a.m. - 6 p.m. local time  
Phone: +86-20-8755-5561

▶ **India**

Monday - Friday  
9 a.m. - 6 p.m. local time  
Phone: +91-124-410-7881

▶ **Japan**

Monday - Friday  
9:30 a.m. - 5:30 p.m. local time  
Phone: +81-3-3523-5991  
Email: support.japan@raritan.com

▶ **Europe**

**Europe**

Monday - Friday  
8:30 a.m. - 5 p.m. GMT+1 CET  
Phone: +31-10-2844040  
Email: tech.europe@raritan.com

**United Kingdom**

Monday - Friday  
8:30 a.m. to 5 p.m. GMT  
Phone +44(0)20-7090-1390

**France**

Monday - Friday  
8:30 a.m. - 5 p.m. GMT+1 CET  
Phone: +33-1-47-56-20-39

**Germany**

Monday - Friday  
8:30 a.m. - 5:30 p.m. GMT+1 CET  
Phone: +49-20-17-47-98-0  
Email: rg-support@raritan.com

▶ **Melbourne, Australia**

Monday - Friday  
9:00 a.m. - 6 p.m. local time  
Phone: +61-3-9866-6887

▶ **Taiwan**

Monday - Friday  
9 a.m. - 6 p.m. GMT -5 Standard -4 Daylight  
Phone: +886-2-8919-1333  
Email: support.apac@raritan.com